

# DONNEES TECHNIQUES



H00K 2

## DONNEES TECHNIQUES

<b>HOOK 2</b>			<b>21</b>	<b>23</b>	<b>25</b>	<b>27</b>	<b>29</b>
ALVEOLES	NOMBRE		50	50	50	50	50
	FERME		6	6	6	6	6
	CAISSONS		27	27	27	27	27
A PLAT	SURFACE	M2	21	23	25	27	29
	ENVERGURE	M	10,55	11,04	11,51	11,96	12,39
	ALLONGEMENT		5,3	5,3	5,3	5,3	5,3
PROJETEE	SURFACE	M2	17,87	19,55	21,23	22,09	24,54
	ENVERGURE	M	8,28	8,65	9,29	9,35	9,68
	ALLONGEMENT		3,82	3,82	3,82	3,82	3,82
APLATISSEMENT		%	15	15	15	15	15
CORDE	MAXIMUM	M	2,45	2,56	2,67	2,77	2,87
	MINIMUM	M	0,57	0,6	0,62	0,65	0,67
	MOYENNE	M	1,99	2,08	2,17	2,25	2,34
SUSPENTES	TOTALES	M	270	276	294	306	317
	HAUTEUR	M	6,59	6,87	7,11	7,41	7,66
	NOMBRE		218	218	218	218	218
	REPARTITION		3/3/4/2	3/3/4/2	3/3/4/2	3/3/4/2	3/3/4/2
ELEVATEURS	NOMBRE	4	A/B/C/D	A/B/C/D	A/B/C/D	A/B/C/D	A/B/C/D
	AFFICHEURS		NO	NO	NO	NO	NO
POIDS TOTAL	MINIMUM	KG	45	65	80	95	110
EN VOL	MAXIMUM	KG	65	85	100	115	130
POIDS DE L'AILE		KG	5	5,3	5,6	5,9	6,2
HOMOLOGATION		EN	B	B	B	B	B

## MATERIAUX

<b>VOILERIE</b>	<b>MATERIAUX</b>	<b>FABRICANT</b>
EXTRADOS	SKYTEX 40 9017 E77A	NCV (FRANCE)
INTRADOS	SKYTEX 40 9017 E38A	NCV (FRANCE)
PROFIL	SKYTEX 40 9017 E29	NCV (FRANCE)
DIAGONALES	SKYTEX 40 9017 E29	NCV (FRANCE)
POINT D'ATTACHE	LKI - 10	KOLON INDUSTRIAL (KOREA)
RENFORT DU POINT D'ATTACHE	W-420	D-P (GERMANY)
RENFORT DU BORD DE FUITE	MYLAR 25 M/M	D-P (GERMANY)
RENFORT CLOISONS	W-420	D-P (GERMANY)
FIL	SERAFIL 60	AMAN (GERMANY)

<b>SUSPENTAGE</b>	<b>MATERIAUX</b>	<b>FABRICANT</b>
CASCADES SUPERIEURES	TNL - 080	TEIJIN LIMITED (JAPAN)
CASCADES INTERMEDIAIRES	TNL - 080	TEIJIN LIMITED (JAPAN)
CASCADES INTERMEDIAIRES	TNL - 140	TEIJIN LIMITED (JAPAN)
CASCADES PRINCIPALES	TNL - 280	TEIJIN LIMITED (JAPAN)
CASCADES PRINCIPALES	TNL - 220	TEIJIN LIMITED (JAPAN)
CASCADES PRINCIPALES FREIN	TNL - 400	TEIJIN LIMITED (JAPAN)
FIL	SERAFIL 60	AMAN (GERMANY)

<b>ELEVATEURS</b>	<b>MATERIAUX</b>	<b>FABRICANT</b>
SANGLES	G-R 22	TECHNI SANGLES (FRANCE)
INDICATEUR DE COULEUR	PAD	TECHNI SANGLES (FRANCE)
FIL	V138	COATS (ENGLAND)
MAILLONS	MRI4	ANSUNG PRECISION (KOREA)
POULIE	224	HARKEN (USA)

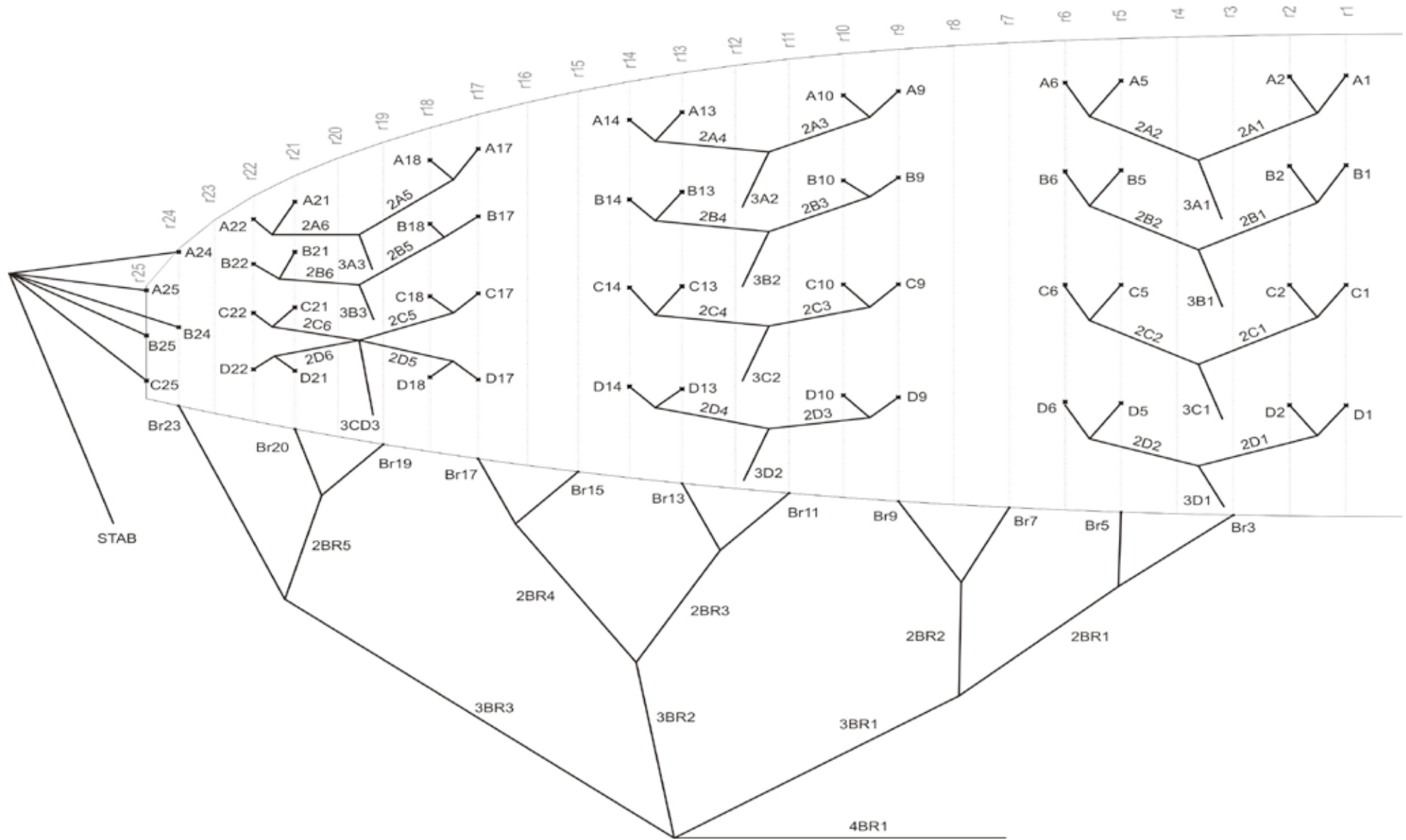

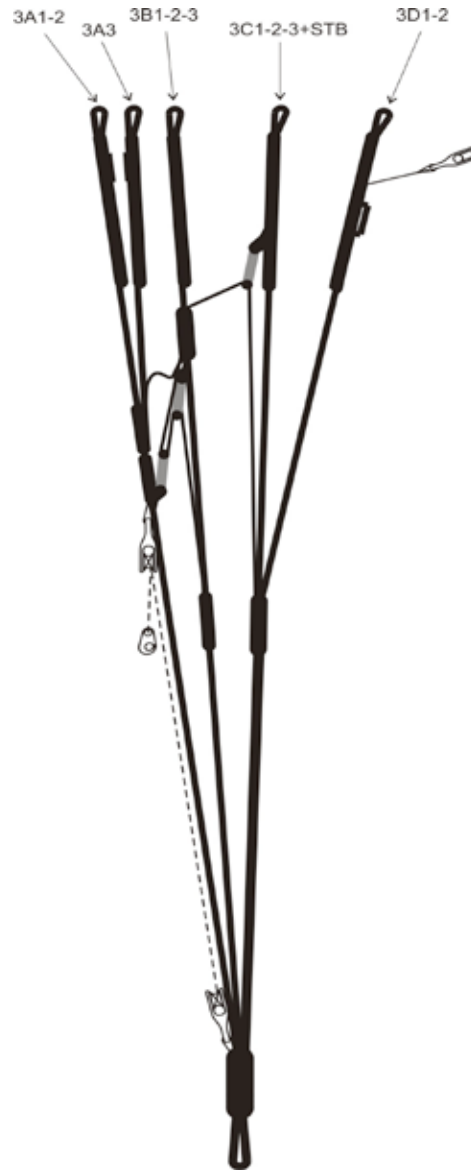

## DONNEES TECHNIQUES DES COULEURS

WIRE	1	ORANGE	COULEUR EXTRADOS	REF: 744
	4	ORANGE	COULEUR INTRADOS	REF: 744
	2	RED DRAGON	MOUSTACHE	REF: 636
	3	WHITE	LISERET	REF: 001



FROST	1	DEEP BLUE	COULEUR EXTRADOS	REF: 354
	4	DEEP BLUE	COULEUR INTRADOS	REF: 354
	2	ROYAL BLUE	MOUSTACHE	REF: 317
	3	WHITE	LISERET	REF: 001



SPRING	1	LIGHT GREEN	COULEUR EXTRADOS	REF: 521
	4	LIGHT GREEN	COULEUR INTRADOS	REF: 521
	2	GREEN	MOUSTACHE	REF: 551
	3	WHITE	LISERET	REF: 001



SANGRIA	1	BORDEAUX	COULEUR EXTRADOS	REF: 615
	4	BORDEAUX	COULEUR INTRADOS	REF: 615
	2	RED DRAGON	MOUSTACHE	REF: 636
	3	WHITE	LISERET	REF: 001

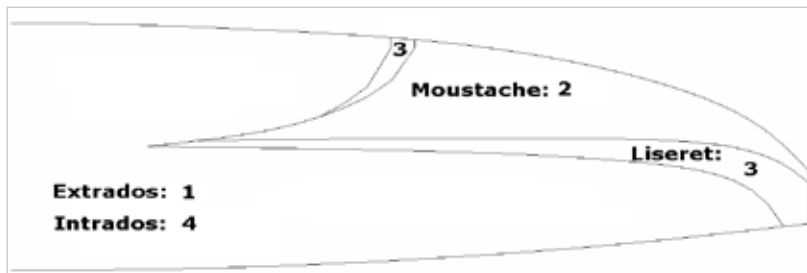

## DONNEES TECHNIQUES CHARGE ALAIRE

HOOK 2 29		27		25		23		21	
P.T.V.	KG/M2	P.T.V.	KG/M2	P.T.V.	KG/M2	P.T.V.	KG/M2	P.T.V.	KG/M2
130 =	4,48	115 =	4,26	100 =	4	85 =	3,70	65 =	3,10
129 =	4,45	114 =	4,22	99 =	3,96	84 =	3,65	64 =	3,05
128 =	4,41	113 =	4,19	98 =	3,92	83 =	3,61	63 =	3
127 =	4,38	112 =	4,15	97 =	3,88	82 =	3,57	62 =	2,95
126 =	4,34	111 =	4,11	96 =	3,84	81 =	3,52	61 =	2,90
125 =	4,31	110 =	4,07	95 =	3,80	80 =	3,48	60 =	2,86
124 =	4,28	109 =	4,04	94 =	3,76	79 =	3,43	59 =	2,81
123 =	4,24	108 =	4	93 =	3,72	78 =	3,39	58 =	2,76
122 =	4,21	107 =	3,96	92 =	3,68	77 =	3,35	57 =	2,71
121 =	4,17	106 =	3,93	91 =	3,64	76 =	3,30	56 =	2,67
120 =	4,14	105 =	3,89	90 =	3,60	75 =	3,26	55 =	2,62
119 =	4,10	104 =	3,85	89 =	3,56	74 =	3,22	54 =	2,57
118 =	4,07	103 =	3,81	88 =	3,52	73 =	3,17	53 =	2,52
117 =	4,03	102 =	3,78	87 =	3,48	72 =	3,13	52 =	2,48
116 =	4	101 =	3,74	86 =	3,44	71 =	3,09	51 =	2,43
115 =	3,97	100 =	3,70	85 =	3,40	70 =	3,04	50 =	2,38
114 =	3,93	99 =	3,67	84 =	3,36	69 =	3	49 =	2,33
113 =	3,90	98 =	3,63	83 =	3,32	68 =	2,96	48 =	2,29
112 =	3,86	97 =	3,59	82 =	3,28	67 =	2,91	47 =	2,24
111 =	3,83	96 =	3,56	81 =	3,24	66 =	2,87	46 =	2,19
110 =	3,79	95 =	3,52	80 =	3,20	65 =	2,83	45 =	2,14

**DONNEES SUSPENTES**

**HOOK 2 21**

REF.	CODE	CM.	REF.	CODE	CM.	REF.	CODE	CM.	REF.	CODE	CM.	REF.	CODE	
<b>A</b>			<b>B</b>			<b>C</b>			<b>D</b>			<b>BRAKE</b>		
A1	TNL-080-YLW	32	B1	TNL-080-BLU	31,5	C1	TNL-080-BLU	32	D1	TNL-080-BLU	32,5	BR3	TNL-080-RED	94
A2	TNL-080-YLW	28	B2	TNL-080-BLU	28	C2	TNL-080-BLU	28	D2	TNL-080-BLU	27,5	BR5	TNL-080-RED	75,5
A5	TNL-080-YLW	29	B5	TNL-080-BLU	29	C5	TNL-080-BLU	29	D5	TNL-080-BLU	28,5	BR7	TNL-080-RED	90,5
A6	TNL-080-YLW	31	B6	TNL-080-BLU	31	C6	TNL-080-BLU	31,5	D6	TNL-080-BLU	32	BR9	TNL-080-RED	86,5
A9	TNL-080-YLW	31	B9	TNL-080-BLU	31	C9	TNL-080-BLU	31	D9	TNL-080-BLU	31,5	BR11	TNL-080-RED	86
A10	TNL-080-YLW	27,5	B10	TNL-080-BLU	27,5	C10	TNL-080-BLU	27,5	D10	TNL-080-BLU	27	BR13	TNL-080-RED	78,5
A13	TNL-080-YLW	27,5	B13	TNL-080-BLU	27	C13	TNL-080-BLU	26,5	D13	TNL-080-BLU	26,5	BR15	TNL-080-RED	74
A14	TNL-080-YLW	29,5	B14	TNL-080-BLU	29	C14	TNL-080-BLU	29	D14	TNL-080-BLU	29,5	BR17	TNL-080-RED	79,5
A17	TNL-080-YLW	31,5	B17	TNL-080-BLU	30,5	C17	TNL-080-BLU	30	D17	TNL-080-BLU	30,5	BR19	TNL-080-RED	70,5
A18	TNL-080-YLW	26,5	B18	TNL-080-BLU	26	C18	TNL-080-BLU	25,5	D18	TNL-080-BLU	25,5	BR21	TNL-080-RED	64
A21	TNL-080-YLW	29	B21	TNL-080-BLU	27	C21	TNL-080-BLU	26	D21	TNL-080-BLU	26	BR24	TNL-080-RED	128,5
A22	TNL-080-YLW	26,5	B22	TNL-080-BLU	24,5	C22	TNL-080-BLU	23	D22	TNL-080-BLU	22,5			
A24	TNL-080-RED	195	B24	TNL-080-RED	192									
A25	TNL-080-RED	184	B25	TNL-080-RED	184,5	C25	TNL-080-RED	187,5						
2 A1	TNL-140-YLW	197	2 B1	TNL-140-BLU	196	2 C1	TNL-140-BLU	180	2 D1	TNL-080-BLU	154,5	2 BR1	TNL-080-RED	116
2 A2	TNL-140-YLW	192,5	2 B2	TNL-140-BLU	191,5	2 C2	TNL-140-BLU	176	2 D2	TNL-080-BLU	150,5	2 BR2	TNL-080-RED	87,5
2 A3	TNL-140-YLW	188,5	2 B3	TNL-140-BLU	186,5	2 C3	TNL-140-BLU	170,5	2 D3	TNL-080-BLU	146,5	2 BR3	TNL-080-RED	90,5
2 A4	TNL-140-YLW	186	2 B4	TNL-140-BLU	185	2 C4	TNL-140-BLU	169	2 D4	TNL-080-BLU	144,5	2 BR4	TNL-080-RED	94,5
2 A5	TNL-140-YLW	161	2 B5	TNL-140-BLU	153	2 C5	TNL-080-BLU	158	2 D5	TNL-080-BLU	164	2 BR5	TNL-080-RED	80,5
2 A6	TNL-140-YLW	143	2 B6	TNL-140-BLU	138	2 C6	TNL-080-BLU	142,5	2 D6	TNL-080-BLU	147			
3 A1	TNL-280-YLW	383	3 B1	TNL-280-BLU	377	3 C1	TNL-280-BLU	394,5	3 D1	TNL-220-BLU	430	3 BR1	TNL-080-RED	257,5
3 A2	TNL-220-YLW	382	3 B2	TNL-220-BLU	378	3 C2	TNL-220-BLU	395,5	3 D2	TNL-220-BLU	428,5	3 BR2	TNL-080-RED	244
3 A3	TNL-220-YLW	390,5	3 B3	TNL-220-BLU	396	3 CD3	TNL-220-BLU	393,5				3 BR3	TNL-080-RED	254
						STAB	TNL-080-RED	340,5				4 BR1	TNL-400-RED	220,5
												POINT AT:		200,5

**DONNEES SUSPENTES**

**HOOK 2 23**

REF.	CODE	CM.	REF.	CODE	CM.	REF.	CODE	CM.	REF.	CODE	CM.	REF.	CODE	
<b>A</b>			<b>B</b>			<b>C</b>			<b>D</b>			<b>BRAKE</b>		
A1	TNL-080-YLW	33,5	B1	TNL-080-BLU	33	C1	TNL-080-BLU	33,5	D1	TNL-080-BLU	34	BR3	TNL-080-RED	98,5
A2	TNL-080-YLW	29,5	B2	TNL-080-BLU	29,5	C2	TNL-080-BLU	29	D2	TNL-080-BLU	29	BR5	TNL-080-RED	79
A5	TNL-080-YLW	30,5	B5	TNL-080-BLU	30,5	C5	TNL-080-BLU	30	D5	TNL-080-BLU	30	BR7	TNL-080-RED	94,5
A6	TNL-080-YLW	32,5	B6	TNL-080-BLU	32,5	C6	TNL-080-BLU	32,5	D6	TNL-080-BLU	33,5	BR9	TNL-080-RED	90,5
A9	TNL-080-YLW	32,5	B9	TNL-080-BLU	32,5	C9	TNL-080-BLU	32,5	D9	TNL-080-BLU	33	BR11	TNL-080-RED	90
A10	TNL-080-YLW	29	B10	TNL-080-BLU	29	C10	TNL-080-BLU	28,5	D10	TNL-080-BLU	28,5	BR13	TNL-080-RED	82
A13	TNL-080-YLW	29	B13	TNL-080-BLU	28	C13	TNL-080-BLU	28	D13	TNL-080-BLU	28	BR15	TNL-080-RED	77,5
A14	TNL-080-YLW	30,5	B14	TNL-080-BLU	30,5	C14	TNL-080-BLU	30,5	D14	TNL-080-BLU	31	BR17	TNL-080-RED	83
A17	TNL-080-YLW	33	B17	TNL-080-BLU	32	C17	TNL-080-BLU	31,5	D17	TNL-080-BLU	32	BR19	TNL-080-RED	74
A18	TNL-080-YLW	28	B18	TNL-080-BLU	27	C18	TNL-080-BLU	26,5	D18	TNL-080-BLU	27	BR21	TNL-080-RED	67
A21	TNL-080-YLW	30	B21	TNL-080-BLU	28	C21	TNL-080-BLU	27	D21	TNL-080-BLU	27	BR24	TNL-080-RED	134,5
A22	TNL-080-YLW	27,5	B22	TNL-080-BLU	26	C22	TNL-080-BLU	24	D22	TNL-080-BLU	23,5			
A24	TNL-080-RED	204	B24	TNL-080-RED	201									
A25	TNL-080-RED	192,5	B25	TNL-080-RED	193	C25	TNL-080-RED	196,5						
2 A1	TNL-140-YLW	206	2 B1	TNL-140-BLU	205	2 C1	TNL-140-BLU	188	2 D1	TNL-080-BLU	161,5	2 BR1	TNL-080-RED	121,5
2 A2	TNL-140-YLW	201,5	2 B2	TNL-140-BLU	200,5	2 C2	TNL-140-BLU	184	2 D2	TNL-080-BLU	157,5	2 BR2	TNL-080-RED	91,5
2 A3	TNL-140-YLW	197,5	2 B3	TNL-140-BLU	195	2 C3	TNL-140-BLU	178	2 D3	TNL-080-BLU	153,5	2 BR3	TNL-080-RED	95
2 A4	TNL-140-YLW	195	2 B4	TNL-140-BLU	194	2 C4	TNL-140-BLU	177	2 D4	TNL-080-BLU	151	2 BR4	TNL-080-RED	99
2 A5	TNL-140-YLW	168,5	2 B5	TNL-140-BLU	160,5	2 C5	TNL-080-BLU	165,5	2 D5	TNL-080-BLU	171,5	2 BR5	TNL-080-RED	84
2 A6	TNL-140-YLW	150	2 B6	TNL-140-BLU	144,5	2 C6	TNL-080-BLU	149	2 D6	TNL-080-BLU	154			
3 A1	TNL-280-YLW	401	3 B1	TNL-280-BLU	394,5	3 C1	TNL-280-BLU	413	3 D1	TNL-220-BLU	450	3 BR1	TNL-080-RED	269,5
3 A2	TNL-220-YLW	400	3 B2	TNL-220-BLU	396	3 C2	TNL-220-BLU	414	3 D2	TNL-220-BLU	448,5	3 BR2	TNL-080-RED	255
3 A3	TNL-220-YLW	409	3 B3	TNL-220-BLU	414,5	3 CD3	TNL-220-BLU	412				3 BR3	TNL-080-RED	265,5
						STAB	TNL-080-RED	356,5				4 BR1	TNL-400-RED	229,5
													POINT AT:	209,5

**DONNEES SUSPENTES**

**HOOK 2**

**25**

REF.	CODE	CM.	REF.	CODE	CM.	REF.	CODE	CM.	REF.	CODE	CM.	REF.	CODE	
<b>A</b>			<b>B</b>			<b>C</b>			<b>D</b>			<b>BRAKE</b>		
A1	TNL-080-YLW	35	B1	TNL-080-BLU	34,5	C1	TNL-080-BLU	35	D1	TNL-080-BLU	35,5	BR3	TNL-080-RED	102,5
A2	TNL-080-YLW	30,5	B2	TNL-080-BLU	30,5	C2	TNL-080-BLU	30,5	D2	TNL-080-BLU	30	BR5	TNL-080-RED	82,5
A5	TNL-080-YLW	32	B5	TNL-080-BLU	31,5	C5	TNL-080-BLU	31,5	D5	TNL-080-BLU	31,5	BR7	TNL-080-RED	98,5
A6	TNL-080-YLW	34	B6	TNL-080-BLU	34	C6	TNL-080-BLU	34	D6	TNL-080-BLU	34,5	BR9	TNL-080-RED	94,5
A9	TNL-080-YLW	34	B9	TNL-080-BLU	33,5	C9	TNL-080-BLU	34	D9	TNL-080-BLU	34,5	BR11	TNL-080-RED	93,5
A10	TNL-080-YLW	30,5	B10	TNL-080-BLU	30	C10	TNL-080-BLU	30	D10	TNL-080-BLU	29,5	BR13	TNL-080-RED	85,5
A13	TNL-080-YLW	30	B13	TNL-080-BLU	29,5	C13	TNL-080-BLU	29	D13	TNL-080-BLU	29	BR15	TNL-080-RED	80,5
A14	TNL-080-YLW	32	B14	TNL-080-BLU	31,5	C14	TNL-080-BLU	31,5	D14	TNL-080-BLU	32,5	BR17	TNL-080-RED	86,5
A17	TNL-080-YLW	34,5	B17	TNL-080-BLU	33	C17	TNL-080-BLU	33	D17	TNL-080-BLU	33	BR19	TNL-080-RED	77
A18	TNL-080-YLW	29	B18	TNL-080-BLU	28,5	C18	TNL-080-BLU	28	D18	TNL-080-BLU	28	BR21	TNL-080-RED	70
A21	TNL-080-YLW	31,5	B21	TNL-080-BLU	29,5	C21	TNL-080-BLU	28	D21	TNL-080-BLU	28	BR24	TNL-080-RED	140,5
A22	TNL-080-YLW	29	B22	TNL-080-BLU	27	C22	TNL-080-BLU	25	D22	TNL-080-BLU	24,5			
A24	TNL-080-RED	212,5	B24	TNL-080-RED	209,5									
A25	TNL-080-RED	200,5	B25	TNL-080-RED	201,5	C25	TNL-080-RED	205						
2 A1	TNL-140-YLW	215	2 B1	TNL-140-BLU	213,5	2 C1	TNL-140-BLU	196	2 D1	TNL-080-BLU	168,5	2 BR1	TNL-080-RED	127
2 A2	TNL-140-YLW	210	2 B2	TNL-140-BLU	209	2 C2	TNL-140-BLU	192	2 D2	TNL-080-BLU	164	2 BR2	TNL-080-RED	95,5
2 A3	TNL-140-YLW	206	2 B3	TNL-140-BLU	203,5	2 C3	TNL-140-BLU	186	2 D3	TNL-080-BLU	160	2 BR3	TNL-080-RED	99
2 A4	TNL-140-YLW	203	2 B4	TNL-140-BLU	202	2 C4	TNL-140-BLU	184,5	2 D4	TNL-080-BLU	157,5	2 BR4	TNL-080-RED	103
2 A5	TNL-140-YLW	175,5	2 B5	TNL-140-BLU	167	2 C5	TNL-080-BLU	172,5	2 D5	TNL-080-BLU	179	2 BR5	TNL-080-RED	87,5
2 A6	TNL-140-YLW	156	2 B6	TNL-140-BLU	150,5	2 C6	TNL-080-BLU	155,5	2 D6	TNL-080-BLU	160,5			
3 A1	TNL-280-YLW	418	3 B1	TNL-280-BLU	411,5	3 C1	TNL-280-BLU	430,5	3 D1	TNL-220-BLU	469,5	3 BR1	TNL-080-RED	281
3 A2	TNL-220-YLW	417	3 B2	TNL-220-BLU	412,5	3 C2	TNL-220-BLU	432	3 D2	TNL-220-BLU	467,5	3 BR2	TNL-080-RED	266
3 A3	TNL-220-YLW	425,7	3 B3	TNL-220-BLU	432	3 CD3	TNL-220-BLU	429,5				3 BR3	TNL-080-RED	276,5
						STAB	TNL-080-RED	369,5				4 BR1	TNL-400-RED	238,5
														POINT AT: 218,5

**DONNEES SUSPENTES**

**HOOK 2 27**

REF.	CODE	CM.	REF.	CODE	CM.	REF.	CODE	CM.	REF.	CODE	CM.	REF.	CODE	
<b>A</b>			<b>B</b>			<b>C</b>			<b>D</b>			<b>BRAKE</b>		
A1	TNL-080-YLW	36	B1	TNL-080-BLU	36	C1	TNL-080-BLU	36	D1	TNL-080-BLU	37	BR3	TNL-080-RED	106,5
A2	TNL-080-YLW	32	B2	TNL-080-BLU	32	C2	TNL-080-BLU	31,5	D2	TNL-080-BLU	31,5	BR5	TNL-080-RED	85,5
A5	TNL-080-YLW	33	B5	TNL-080-BLU	33	C5	TNL-080-BLU	32,5	D5	TNL-080-BLU	32,5	BR7	TNL-080-RED	102,5
A6	TNL-080-YLW	35,5	B6	TNL-080-BLU	35	C6	TNL-080-BLU	35,5	D6	TNL-080-BLU	36	BR9	TNL-080-RED	98
A9	TNL-080-YLW	35,5	B9	TNL-080-BLU	35	C9	TNL-080-BLU	35,5	D9	TNL-080-BLU	36	BR11	TNL-080-RED	97,5
A10	TNL-080-YLW	31,5	B10	TNL-080-BLU	31,5	C10	TNL-080-BLU	31	D10	TNL-080-BLU	30,5	BR13	TNL-080-RED	89
A13	TNL-080-YLW	31	B13	TNL-080-BLU	30,5	C13	TNL-080-BLU	30	D13	TNL-080-BLU	30	BR15	TNL-080-RED	84
A14	TNL-080-YLW	33,5	B14	TNL-080-BLU	33	C14	TNL-080-BLU	33	D14	TNL-080-BLU	33,5	BR17	TNL-080-RED	90
A17	TNL-080-YLW	35,5	B17	TNL-080-BLU	34,5	C17	TNL-080-BLU	34	D17	TNL-080-BLU	34,5	BR19	TNL-080-RED	80
A18	TNL-080-YLW	30	B18	TNL-080-BLU	29,5	C18	TNL-080-BLU	29	D18	TNL-080-BLU	29	BR21	TNL-080-RED	72,5
A21	TNL-080-YLW	32,5	B21	TNL-080-BLU	30,5	C21	TNL-080-BLU	29,5	D21	TNL-080-BLU	29,5	BR24	TNL-080-RED	146
A22	TNL-080-YLW	30	B22	TNL-080-BLU	28	C22	TNL-080-BLU	26	D22	TNL-080-BLU	25,5			
A24	TNL-080-RED	219,5	B24	TNL-080-RED	217,5									
A25	TNL-080-RED	208,5	B25	TNL-080-RED	209,5	C25	TNL-080-RED	213,5						
2 A1	TNL-140-YLW	223,5	2 B1	TNL-140-BLU	222	2 C1	TNL-140-BLU	204	2 D1	TNL-080-BLU	175	2 BR1	TNL-080-RED	132
2 A2	TNL-140-YLW	218	2 B2	TNL-140-BLU	217,5	2 C2	TNL-140-BLU	199,5	2 D2	TNL-080-BLU	170,5	2 BR2	TNL-080-RED	99
2 A3	TNL-140-YLW	214	2 B3	TNL-140-BLU	211,5	2 C3	TNL-140-BLU	193	2 D3	TNL-080-BLU	166	2 BR3	TNL-080-RED	102,5
2 A4	TNL-140-YLW	211	2 B4	TNL-140-BLU	210	2 C4	TNL-140-BLU	192	2 D4	TNL-080-BLU	163,5	2 BR4	TNL-080-RED	107
2 A5	TNL-140-YLW	182,5	2 B5	TNL-140-BLU	173,5	2 C5	TNL-080-BLU	179	2 D5	TNL-080-BLU	186	2 BR5	TNL-080-RED	91
2 A6	TNL-140-YLW	162,5	2 B6	TNL-140-BLU	156,5	2 C6	TNL-080-BLU	161,5	2 D6	TNL-080-BLU	167			
3 A1	TNL-280-YLW	434,5	3 B1	TNL-280-BLU	427,5	3 C1	TNL-280-BLU	447,5	3 D1	TNL-220-BLU	488	3 BR1	TNL-080-RED	291,5
3 A2	TNL-220-YLW	433,5	3 B2	TNL-220-BLU	429	3 C2	TNL-220-BLU	449	3 D2	TNL-220-BLU	486	3 BR2	TNL-080-RED	276
3 A3	TNL-220-YLW	442,5	3 B3	TNL-220-BLU	449	3 CD3	TNL-220-BLU	446,5				3 BR3	TNL-080-RED	288
						STAB	TNL-080-RED	386,5				4 BR1	TNL-400-RED	247,5
														POINT AT: 227,5

**DONNEES SUSPENTES**

**HOOK 2**

**29**

REF.	CODE	CM.	REF.	CODE	CM.	REF.	CODE	CM.	REF.	CODE	CM.	REF.	CODE	
<b>A</b>			<b>B</b>			<b>C</b>			<b>D</b>			<b>BRAKE</b>		
A1	TNL-080-YLW	38	B1	TNL-080-BLU	37,5	C1	TNL-080-BLU	38	D1	TNL-080-BLU	38,5	BR3	TNL-080-RED	111,5
A2	TNL-080-YLW	33,5	B2	TNL-080-BLU	33	C2	TNL-080-BLU	33	D2	TNL-080-BLU	32,5	BR5	TNL-080-RED	89,5
A5	TNL-080-YLW	34,5	B5	TNL-080-BLU	34,5	C5	TNL-080-BLU	34	D5	TNL-080-BLU	34	BR7	TNL-080-RED	107
A6	TNL-080-YLW	37	B6	TNL-080-BLU	36,5	C6	TNL-080-BLU	37	D6	TNL-080-BLU	37,5	BR9	TNL-080-RED	102,5
A9	TNL-080-YLW	37	B9	TNL-080-BLU	36,5	C9	TNL-080-BLU	37	D9	TNL-080-BLU	37,5	BR11	TNL-080-RED	102
A10	TNL-080-YLW	33	B10	TNL-080-BLU	33	C10	TNL-080-BLU	32,5	D10	TNL-080-BLU	32	BR13	TNL-080-RED	93
A13	TNL-080-YLW	32,5	B13	TNL-080-BLU	32	C13	TNL-080-BLU	31,5	D13	TNL-080-BLU	31,5	BR15	TNL-080-RED	87,5
A14	TNL-080-YLW	35	B14	TNL-080-BLU	34,5	C14	TNL-080-BLU	34,5	D14	TNL-080-BLU	35	BR17	TNL-080-RED	94
A17	TNL-080-YLW	37,5	B17	TNL-080-BLU	36	C17	TNL-080-BLU	35,5	D17	TNL-080-BLU	36	BR19	TNL-080-RED	84
A18	TNL-080-YLW	31,5	B18	TNL-080-BLU	30,5	C18	TNL-080-BLU	30,5	D18	TNL-080-BLU	30,5	BR21	TNL-080-RED	76
A21	TNL-080-YLW	34	B21	TNL-080-BLU	32	C21	TNL-080-BLU	30,5	D21	TNL-080-BLU	30,5	BR24	TNL-080-RED	152,5
A22	TNL-080-YLW	31,5	B22	TNL-080-BLU	29	C22	TNL-080-BLU	27	D22	TNL-080-BLU	26,5			
A24	TNL-080-RED	231	B24	TNL-080-RED	227,5									
A25	TNL-080-RED	218	B25	TNL-080-RED	219	C25	TNL-080-RED	223,5						
2 A1	TNL-140-YLW	233,5	2 B1	TNL-140-BLU	232	2 C1	TNL-140-BLU	213	2 D1	TNL-080-BLU	183	2 BR1	TNL-080-RED	138
2 A2	TNL-140-YLW	228	2 B2	TNL-140-BLU	227,5	2 C2	TNL-140-BLU	208,5	2 D2	TNL-080-BLU	178	2 BR2	TNL-080-RED	103,5
2 A3	TNL-140-YLW	223,5	2 B3	TNL-140-BLU	221	2 C3	TNL-140-BLU	202	2 D3	TNL-080-BLU	173,5	2 BR3	TNL-080-RED	107,5
2 A4	TNL-140-YLW	220,5	2 B4	TNL-140-BLU	219,5	2 C4	TNL-140-BLU	200,5	2 D4	TNL-080-BLU	171	2 BR4	TNL-080-RED	112
2 A5	TNL-140-YLW	190,5	2 B5	TNL-140-BLU	181,5	2 C5	TNL-080-BLU	187	2 D5	TNL-080-BLU	194	2 BR5	TNL-080-RED	95,5
2 A6	TNL-140-YLW	169,5	2 B6	TNL-140-BLU	163,5	2 C6	TNL-080-BLU	169	2 D6	TNL-080-BLU	174,5			
3 A1	TNL-280-YLW	454	3 B1	TNL-280-BLU	447	3 C1	TNL-280-BLU	468	3 D1	TNL-220-BLU	510	3 BR1	TNL-080-RED	304,5
3 A2	TNL-220-YLW	453	3 B2	TNL-220-BLU	448	3 C2	TNL-220-BLU	469	3 D2	TNL-220-BLU	508	3 BR2	TNL-080-RED	288,5
3 A3	TNL-220-YLW	463,5	3 B3	TNL-220-BLU	469,5	3 CD3	TNL-220-BLU	466,5				3 BR3	TNL-080-RED	300,5
						STAB	TNL-080-RED	403,5				4 BR1	TNL-400-RED	257,5
														POINT AT: 237,5

**NIVIUK HOOK 2 21**

LONGUEURS TOTALES CM.						
	<b>A</b>	<b>B</b>	<b>C</b>	<b>D</b>	<b>BR</b>	<b>RIP.</b>
1	609,5	630	632	643	700	3
2	605,5	626,5	627,5	638	680,5	5
5	602	623	624,5	635	666	7
6	604	625	627	638,5	662	9
9	599	621	622	632,5	650,5	11
10	595,5	617,5	618	628	642,5	13
13	593	615,5	616,5	625	642	15
14	595	618	619	628	647,5	17
17	580,5	604,5	607	613,5	634	19
18	575,5	599,5	602	608,5	627	21
21	560	584,5	586	591	610,5	24
22	557,5	582,5	583	587,5		
24	533,5	556,5				
25	522,5	548,5	552			

LONGUEURS DES ELEVATEURS CM.					
	<b>A</b>	<b>B</b>	<b>C</b>	<b>D</b>	
	47	47	47	47	NEUTRE
	38	41	43,5	47	ACCELEREE

**NIVIUK HOOK 2 23**

LONGUEURS TOTALES CM.						
	<b>A</b>	<b>B</b>	<b>C</b>	<b>D</b>	<b>BR</b>	<b>RIP.</b>
1	638	630	632	643	700	3
2	634	626,5	627,5	638	680,5	5
5	630,5	623	624,5	635	666	7
6	632,5	625	627	638,5	662	9
9	627,5	621	622	632,5	650,5	11
10	624	617,5	618	628	642,5	13
13	621,5	615,5	616,5	625	642	15
14	623	618	619	628	647,5	17
17	608	604,5	607	613,5	634	19
18	603	599,5	602	608,5	627	21
21	586,5	584,5	586	591	610,5	24
22	584	582,5	583	587,5		
24	559,5	556,5				
25	548	548,5	552			

LONGUEURS DES ELEVATEURS CM.					
	<b>A</b>	<b>B</b>	<b>C</b>	<b>D</b>	
	47	47	47	47	NEUTRE
	32	35	41	47	ACCELEREE

**NIVIUK HOOK 2 25**

LONGUEURS TOTALES CM.						
	<b>A</b>	<b>B</b>	<b>C</b>	<b>D</b>	<b>BR</b>	<b>RIP.</b>
1	665,5	657	659	671	727	3
2	661	653	654,5	665,5	707	5
5	657,5	649,5	651,5	662,5	691,5	7
6	659,5	652	654	665,5	687,5	9
9	654,5	647	649,5	659,5	675	11
10	651	643,5	645,5	654,5	667	13
13	647,5	641,5	643	651,5	666	15
14	649,5	643,5	645,5	655	672	17
17	633,2	629,5	632,5	639	657,5	19
18	627,7	625	627,5	634	650,5	21
21	610,2	609	610	615	633,5	24
22	607,7	606,5	607	611,5		
24	580	577				
25	568	569	572,5			

LONGUEURS DES ELEVATEURS CM.					
	<b>A</b>	<b>B</b>	<b>C</b>	<b>D</b>	
	47	47	47	47	NEUTRE
	32	35	41	47	ACCELEREE

**NIVIUK HOOK 2 27**

LONGUEURS TOTALES CM.						
	<b>A</b>	<b>B</b>	<b>C</b>	<b>D</b>	<b>BR</b>	<b>RIP.</b>
1	691,5	683	685	697,5	753,5	3
2	687,5	679	680,5	692	732,5	5
5	683	675,5	677	688,5	716,5	7
6	685,5	677,5	680	692	712	9
9	680,5	673	675	685,5	699,5	11
10	676,5	669,5	670,5	680	691	13
13	673	667	668,5	677	690,5	15
14	675,5	669,5	671,5	680,5	696,5	17
17	658	654,5	657	664,5	682,5	19
18	652,5	649,5	652	659	675	21
21	634,5	633	634,5	640	657,5	24
22	632	630,5	631	636		
24	603	601				
25	592	593	597			

LONGUEURS DES ELEVATEURS CM.					
	<b>A</b>	<b>B</b>	<b>C</b>	<b>D</b>	
	47	47	47	47	NEUTRE
	32	35	41	47	ACCELEREE

LONGUEURS TOTALES CM.

	<b>A</b>	<b>B</b>	<b>C</b>	<b>D</b>	<b>BR</b>	<b>RIP.</b>
1	724,5	715,1	718,2	730,9	790	3
2	719,9	710,6	713,2	724,9	768	5
5	715,3	707,7	709,7	721,3	751	7
6	718	709,9	713	724,9	746,5	9
9	712,7	704,7	707,2	717,9	734	11
10	708,7	701,4	702,7	712,3	725	13
13	705,3	698,9	700	709,2	724	15
14	707,7	701,4	702,9	712,8	730,5	17
17	689,9	685,8	687,7	695,1	716	19
18	684	680,1	682,6	689,7	708	21
21	665,4	663,9	664,6	670,1	689	24
22	662,7	660,9	660,9	665,6		
24	633,4	629,7				
25	620,4	621,3	625,9			

LONGUEURS DES ELEVATEURS CM.

	<b>A</b>	<b>B</b>	<b>C</b>	<b>D</b>	
	47	47	47	47	NEUTRE
	32	35	41	47	ACCELEREE



**DONNEES TECHNIQUES TISSU EXTRADOS****DESCRIPTION**

SKYTEX 40 REPELLANT	REF. : F09017 - E77A
TISSU	9017
TYPE DE FINITION	SIDE COATED (POLYURETHANE)
TYPE DE FIL	POLYAMIDE 6.6 HIGH TENACITY – 33 DTEX
LARGEUR	158 CM
CHABLON	RIP STOP

**SPECIFICATIONS TECHNIQUES**

POIDS DU TISSU ENDUIT	G/SQM	ISO 2286-2	40 +/- 2
RESISTANCE A LA DECHIRURE - SENS CHAINE	DAN	ISO 4674	1,5 MINI
RESISTANCE A LA DECHIRURE - SENS TRAME	DAN	ISO 4674	1,5 MINI
ALLONGEMENT DANS LE BIAIS A 3 LBS	% INTERNAL METHOD NCV 044		8 MAX
ALLONGEMENT DANS LE BIAIS A 5 LBS	% INTERNAL METHOD NCV 044		16,5 MAX
ALLONGEMENT DANS LE BIAIS A 10 LBS	% INTERNAL METHOD NCV 044		28 MAX
RESISTANCE A LA RUPTURE	DAN	ISO 1421	38 MINI
SENS CHAINE			
RESISTANCE A LA RUPTURE SENS TRAME	DAN	ISO 1421	33 MINI
PERMEABILITE A L'AIR			
	1/SQM/MN	2000 PA	40 MAX
	* UNDER	100 CM2	
	SURFACE		

**SPECIFICATIONS TECHNIQUES DES COULEURS**

DEEP BLUE	REF. 354	UV 5-6
GREEN	REF. 551	UV 5
GOLD	REF. 939	UV 5-6
SUNFLOWER	REF. 921	UV 5-6
RED	REF. 633	UV 5
DARK RED	REF. 615	UV 6-7
ROYAL BLUE	REF. 317	UV 5
LIGHT GREEN	REF. 521	UV 5-6
ORANGE	REF. 744	UV 4
RED DRAGON	REF. 636	UV 5-6
WHITE	REF. 001	UV 4
GREY	REF. 120	UV 3-4
DARK GREY	REF. 121	UV 4
BLACK	REF. 102	UV 5-6

**DONNEES TECHNIQUES TISSU INTRADOS****DESCRIPTION**

SKYTEX 40 CLASSIC	REF. : F09017 - E38
TISSU	9017
TYPE DE FINITION	SIDE COATED (POLYURETHANE)
TYPE DE FIL	POLYAMIDE 6.6 HIGH TENACITY – 33 DTEX
LARGEUR	158 CM
CHABLON	RIP STOP

**SPECIFICATIONS TECHNIQUES**

POIDS DU TISSU ENDUIT	G/SQM	ISO 2286-2	40 +/- 2
RESISTANCE A LA DECHIRURE - SENS CHAINE	DAN	ISO 4674	1,5 MINI
RESISTANCE A LA DECHIRURE - SENS TRAME	DAN	ISO 4674	1,5 MINI
ALLONGEMENT DANS LE BIAIS A 3 LBS	% INTERNAL METHOD NCV 044		8 MAX
ALLONGEMENT DANS LE BIAIS A 5 LBS	% INTERNAL METHOD NCV 044		16,5 MAX
ALLONGEMENT DANS LE BIAIS A 10 LBS	% INTERNAL METHOD NCV 044		28 MAX
RESISTANCE A LA RUPTURE	DAN	ISO 1421	38 MINI
SENS CHAINE			
RESISTANCE A LA RUPTURE SENS TRAME	DAN	ISO 1421	33 MINI
PERMEABILITE A L'AIR			
	1/SQM/MN	2000 PA	40 MAX
	* UNDER	100 CM2	
	SURFACE		

**SPECIFICATIONS TECHNIQUES DES COULEURS**

DEEP BLUE	REF. 354	UV 5-6
GREEN	REF. 551	UV 5
GOLD	REF. 939	UV 5-6
SUNFLOWER	REF. 921	UV 5-6
RED	REF. 633	UV 5
DARK RED	REF. 615	UV 6-7
ROYAL BLUE	REF. 317	UV 5
LIGHT GREEN	REF. 521	UV 5-6
ORANGE	REF. 744	UV 4
RED DRAGON	REF. 636	UV 5-6
WHITE	REF. 001	UV 4
GREY	REF. 120	UV 3-4
DARK GREY	REF. 121	UV 4
BLACK	REF. 102	UV 5-6

## DONNEES TECHNIQUES MAILLON & POULIE

### DESCRIPTION

MAILLON	DELTA
REF.	MRI4
MATERIEL	STAINLESS STEEL
DIAMETRE	4,3 M/M
POIDS	12 G/PC

### SPECIFICATIONS TECHNIQUES

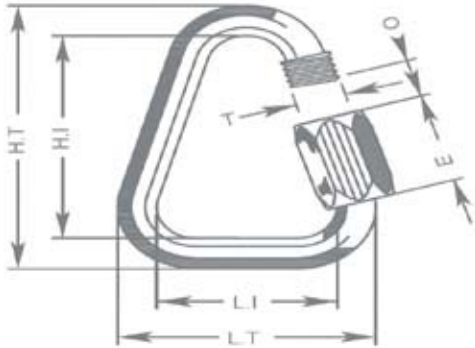

DIMENSIONS	M/M
L.T.	28
L.I.	20
H.T.	38
H.I.	30
O	4
E	11
T	4
CHARGE	KG
UTILE	150
RUPTURE	750

### CONTROLE SYSTEMATIQUE DES MAILLONS RAPIDES AVANT CHAQUE VOL.

### POULIE DESCRIPTION

POULIE	MICRO
REF.	224
MATERIEL	STAINLESS STEEL
COUSSINET	DELTRIN®
POIDS	14 G/PC

### SPECIFICATIONS TECHNIQUES

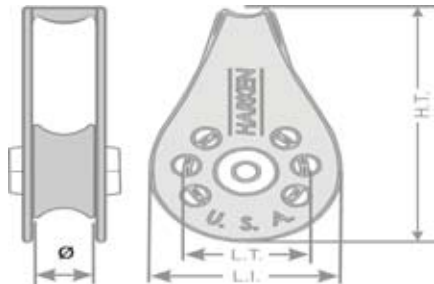

DIMENSIONS	M/M
L.T.	22
L.I.	34
H.T.	38
H.I.	
Ø	6 MAX
CHARGE	KG
UTILE	91
RUPTURE	544

## DONNEES TECHNIQUES FIL

NOM	SERAFIL
N° DE REFERENCE	60
MATERIEL	POLYESTER
FINITION	SILK
DENSITE LINEAIRE	NM 61 / 3 (DTEX 163 * 3)
CHARGE DE RUPTURE	3.000 CN
ALLONGEMENT	17,00%

### PROPRIETE SERAFIL

SOLIDITE A LA LUMIERE ARTIFICIELLE	ISO 105 B02	> 5 - 6
SOLIDITE A LA SUEUR	ISO 105 E04	> 4
SOLIDITE AU LAVAGE	ISO 105 C04	> 3
SOLIDITE AU FROTTEMENT A SEC	ISO 105 X12	> 4
SOLIDITE AU LAVAGE EN SECHERESSE	ISO 105 D01	> 3 - 4

DEPERLANT	WR
-----------	----

NOM	BONDED C.F.P.
N° DE REFERENCE	V138
MATERIEL	POLYESTER
FINITION	SILK
DENSITE LINEAIRE	
CHARGE DE RUPTURE	9,5 KG
ALLONGEMENT	11/19%

## DONNEES TECHNIQUES SANGLES

### ELEVATEURS

REFERENCE	G-R 22
MATERIEL	POLYESTER
LARGEUR	22 M/M
EPAISSEUR	1,52 M/M
CHARGE DE RUPTURE	1.100 DAN
ALLONGEMENT	MAX 15%
POIDS	25 G/M
COULEUR	BLACK

### INDICATEUR DE COULEUR

REFERENCE	IC-G 1-2
MATERIEL	POLYESTER
LARGEUR	70 M/M
EPAISSEUR	0,80 M/M
CHARGE DE RUPTURE	130 DN
ALLONGEMENT	35%
POIDS	32 G/M

### POINT D'ATTACHE

REFERENCE	LKI - 10
MATERIEL	NYLON
LARGEUR	10 M/M
CHARGE DE RUPTURE	84 KG
ALLONGEMENT	25/35%
POIDS	3 G/M
COULEUR	WHITE

**nIVIUK**

[niviuk.com](http://niviuk.com)

The importance of small details