

**DONNÉES
TECHNIQUES
IKUMA**



DONNÉES TECHNIQUES

IKUMA			21	23	25	27	29
ALVÉOLES	NOMBRE		57	57	57	57	57
	FERMÉS		12	12	12	12	12
	CAISSONS	m ²	21	21	21	21	21
À PLAT	SURFACE	m ²	21	23	24,5	26,5	29
	ENVERGURE	m	10,94	11,45	11,82	12,29	12,86
	ALLONGEMENT		5,7	5,7	5,7	5,7	5,7
PROJETÉE	SURFACE	m ²	17,83	19,53	20,75	22,44	24,56
	ENVERGURE	M	8,72	9,13	9,42	9,8	10,25
	ALLONGEMENT		4,26	4,26	4,26	4,26	4,26
APLATISSEMENT		%	15	15	15	15	15
CORDE	MAXIMUM	m	2,33	2,44	2,52	2,62	2,74
	MINIMUM	m	0,54	0,56	0,58	0,61	0,63
	MOYENNE	m	1,92	2,01	2,07	2,16	2,26
SUSPENTES	METRES TOTALES	m	220	230	238	247	259
	HAUTEUR	m	6,67	6,98	7,2	7,49	7,83
	NOMBRE		165	165	165	165	165
	PRINCIPALES		2/1/1/3	2/1/1/3	2/1/1/3	2/1/1/3	2/1/1/3
ÉLÉVATEURS	NOMBRE	4	A/B'/B/C	A/B'/B/C	A/B'/B/C	A/B'/B/C	A/B'/B/C
	AFFICHEURS		NON	NON	NON	NON	NON
	ACCÉLÉRATEUR	m/m	123	123	123	123	123
POIDS TOTAL	MINIMUM	kg	55	65	80	95	110
EN VOL	MAXIMUM	kg	75	85	100	115	130
POIDS DE L'AILE		kg	4,4	4,8	5	5,3	5,7
HOMOLOGATION		EN/LTF	B	B	B	B	B

MATERIAUX

VOILERIE	MATERIAUX	FABRICANT
EXTRADOS	9017 E25	PORCHER IND (FRANCE)
INTRADOS	N20DMF	DOMINICO TEX CO (KOREA)
PROFIL SANS POINT D'ATTACHE	9017 E29	PORCHER IND (FRANCE)
DIAGONALES	9017 E29	PORCHER IND (FRANCE)
POINT D'ATTACHE	LKI - 10	KOLON IND. (KOREA)
RENFORT DU POINT D'ATTACHE	W-420	D-P (GERMANY)
RENFORT DU BORD DE FUITE	MYLAR	D-P (GERMANY)
RENFORT CLOISONS	LTN-0.8 STICK	SPORTWARE CO. (CHINA)
FIL	SERAFIL 60	AMAN (GERMANY)

SUSPENTAGE	MATERIAUX	FABRICANT
CASCADES SUPERIEURES	DC - 040	LIROS GMHB (GERMANY)
CASCADES SUPERIEURES	DC - 060	LIROS GMHB (GERMANY)
CASCADES SUPERIEURES	DC - 100	LIROS GMHB (GERMANY)
CASCADES SUPERIEURES	A-8000/U 50	EDELRID (GERMANY)
CASCADES INTERMEDIAIRES	TNL - 080	TEIJIM LIMITED (JAPAN)
CASCADES INTERMEDIAIRES	DC - 060	LIROS GMHB (GERMANY)
CASCADES INTERMEDIAIRES	A-8000/U 50	EDELRID (GERMANY)
CASCADES INTERMEDIAIRES	A-8000/U 130	EDELRID (GERMANY)
CASCADES INTERMEDIAIRES	A-8000/U 190	EDELRID (GERMANY)
CASCADES PRINCIPALES	A-8000/U 70	EDELRID (GERMANY)
CASCADES PRINCIPALES	A-8000/U 230	EDELRID (GERMANY)
CASCADES PRINCIPALES	A-8000/U 360	EDELRID (GERMANY)
CASCADES PRINCIPALES FREIN	TNL - 280	TEIJIM LIMITED (JAPAN)
FIL	SERAFIL 60	AMAN (GERMANY)

ÉLÉVATEURS	MATERIAUX	FABRICANT
SANGLES	3455	COUSIN (FRANCE)
INDICATEUR DE COULEUR	PAD	TECNI SANGLES (FRANCE)
FIL	N/F-66	YOUNG CHANG T&C LTD
MAILLONS	3.5	ANSUNG PRECISION (KOREA)
POULIE	ID018041	RONSTAN (AUSTRALIA)

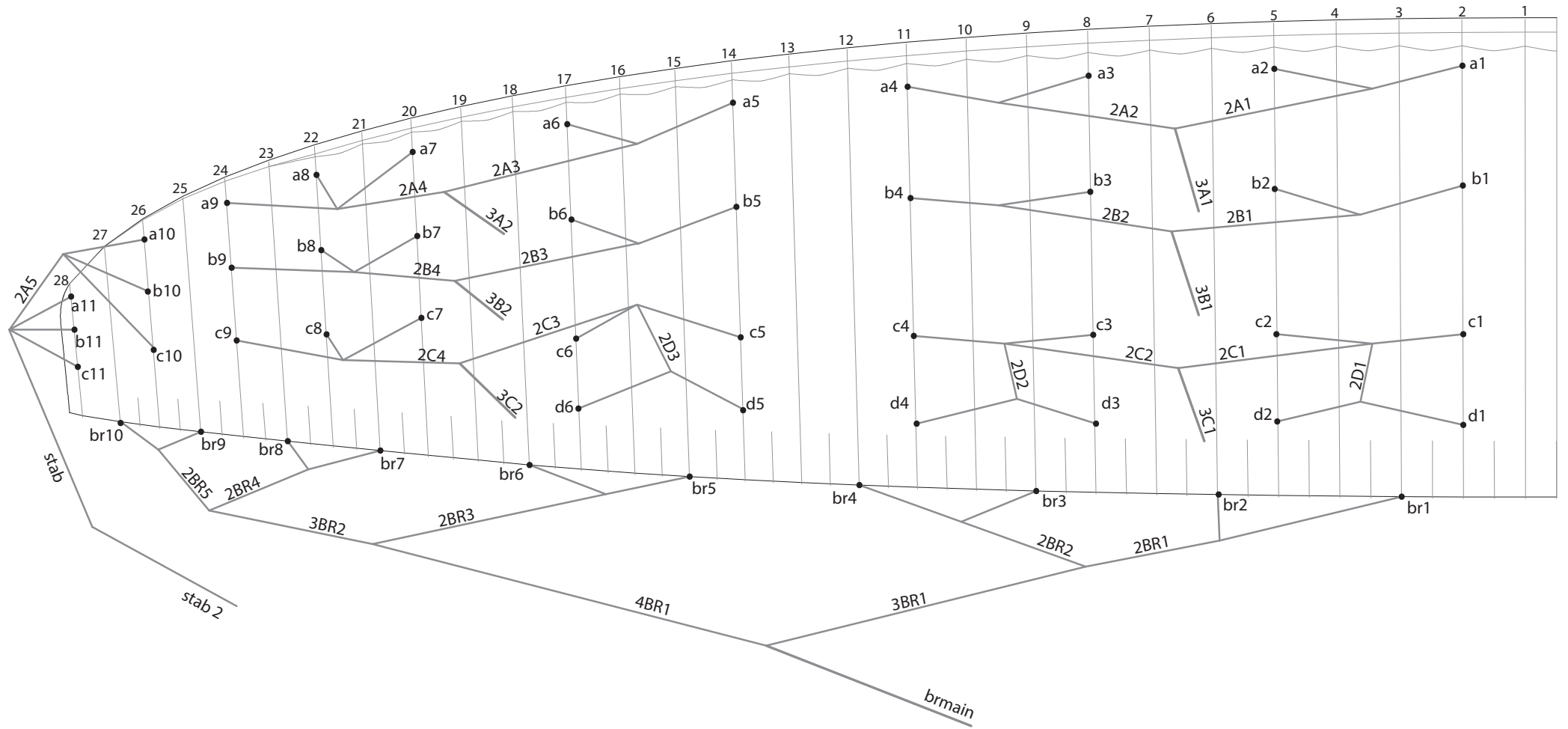

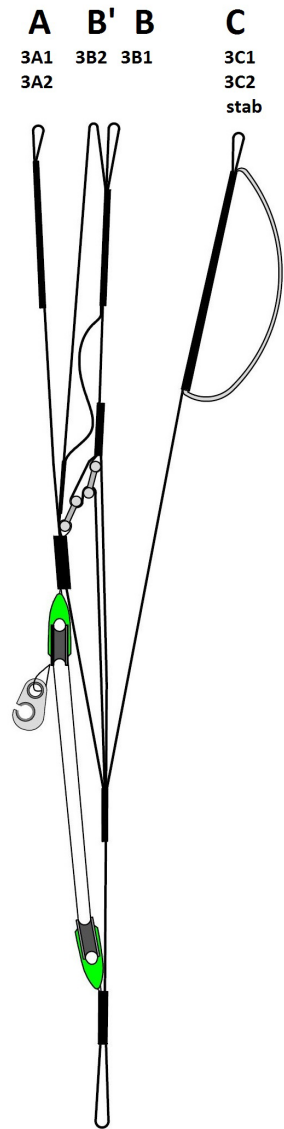

DONNÉES TECHNIQUES DES COULEURS

BLUEBERRY	SB1	ROYAL BLUE	EXTRADOS	REF: 317
	SB2	ROYAL BLUE	INTRADOS	REF: 317
	SB3	RUBI	MOUSTACHE	REF: NK 259
	SB4	WHITE	LISERE	REF: 001
	SB5	BLACK	SECOND LISERET	REF: 102

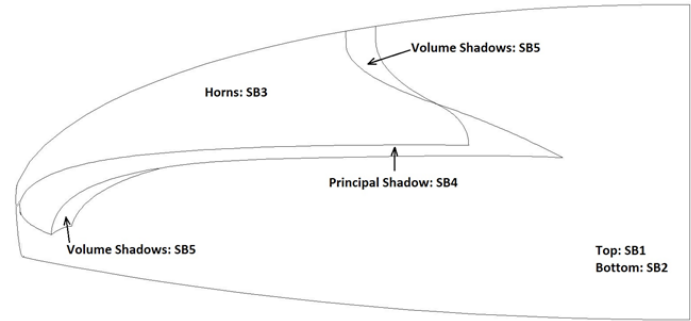

ORCHID	SB1	LIMA	EXTRADOS	REF: NK 375
	SB2	LIMA	INTRADOS	REF: NK 375
	SB3	WHITE	MOUSTACHE	REF: 001
	SB4	RUBI	LISERE	REF: NK 259
	SB5	BLACK	SECOND LISERET	REF: 102



SUNRISE	SB1	ORANGE	EXTRADOS	REF: 744
	SB2	ORANGE	INTRADOS	REF: 744
	SB3	ROYAL BLUE	MOUSTACHE	REF: 317
	SB4	WHITE	LISERE	REF: 001
	SB5	BLACK	SECOND LISERET	REF: 102



TULIP	SB1	DRAGON RED	EXTRADOS	REF: 636
	SB2	DRAGON RED	INTRADOS	REF: 636
	SB3	WHITE	MOUSTACHE	REF: 001
	SB4	LIMA	LISERE	REF: NK 375
	SB5	BLACK	SECOND LISERET	REF: 102



DONNÉES TECHNIQUES CHARGE ALAIRE

IKUMA

21		23		25		27		29	
P.T.V.	kg/m ²	P.T.V.	kg/m ²	P.T.V.	kg/m ²	P.T.V.	kg/m ²	P.T.V.	kg/m ²
55	= 2,62	65	= 2,83	80	= 3,27	95	= 3,58	110	= 3,79
56	= 2,67	66	= 2,87	81	= 3,31	96	= 3,62	111	= 3,83
57	= 2,71	67	= 2,91	82	= 3,35	97	= 3,66	112	= 3,86
58	= 2,76	68	= 2,96	83	= 3,39	98	= 3,70	113	= 3,90
59	= 2,81	69	= 3,00	84	= 3,43	99	= 3,74	114	= 3,93
60	= 2,86	70	= 3,04	85	= 3,47	100	= 3,77	115	= 3,97
61	= 2,90	71	= 3,09	86	= 3,51	101	= 3,81	116	= 4,00
62	= 2,95	72	= 3,13	87	= 3,55	102	= 3,85	117	= 4,03
63	= 3,00	73	= 3,17	88	= 3,59	103	= 3,89	118	= 4,07
64	= 3,05	74	= 3,22	89	= 3,63	104	= 3,92	119	= 4,10
65	= 3,10	75	= 3,26	90	= 3,67	105	= 3,96	120	= 4,14
66	= 3,14	76	= 3,30	91	= 3,71	106	= 4,00	121	= 4,17
67	= 3,19	77	= 3,35	92	= 3,76	107	= 4,04	122	= 4,21
68	= 3,24	78	= 3,39	93	= 3,80	108	= 4,08	123	= 4,24
69	= 3,29	79	= 3,43	94	= 3,84	109	= 4,11	124	= 4,28
70	= 3,33	80	= 3,48	95	= 3,88	110	= 4,15	125	= 4,31
71	= 3,38	81	= 3,52	96	= 3,92	111	= 4,19	126	= 4,34
72	= 3,43	82	= 3,57	97	= 3,96	112	= 4,23	127	= 4,38
73	= 3,48	83	= 3,61	98	= 4,00	113	= 4,26	128	= 4,41
74	= 3,52	84	= 3,65	99	= 4,04	114	= 4,30	129	= 4,45
75	= 3,57	85	= 3,70	100	= 4,08	115	= 4,34	130	= 4,48

DONNÉES SUSPENTES

IKUMA					21																			
REF.	MAT.	KG	COLOR	m/m	REF.	MAT.	KG	COLOR	m/m	REF.	MAT.	KG	COLOR	m/m	REF.	MAT.	KG	COLOR	m/m	REF.	MAT.	KG	COLOR	m/m
A					B					C					D					BRAKE				
a1	DC	100	WHT	1.533	b1	DC	100	WHT	1.509	c1	DC	60	WHT	1.207	d1	DC	40	WHT	1.025	br1	DC	40	WHT	1.067
a2	DC	100	WHT	1.417	b2	DC	100	WHT	1.395	c2	DC	60	WHT	1.054	d2	DC	40	WHT	882	br2	DC	40	WHT	640
a3	DC	100	WHT	1.426	b3	DC	100	WHT	1.404	c3	DC	60	WHT	1.072	d3	DC	40	WHT	895	br3	DC	40	WHT	934
a4	DC	100	WHT	1.455	b4	DC	100	WHT	1.439	c4	DC	60	WHT	1.164	d4	DC	40	WHT	975	br4	DC	40	WHT	969
a5	DC	100	WHT	1.354	b5	DC	100	WHT	1.330	c5	DC	60	WHT	1.019	d5	DC	40	WHT	906	br5	DC	40	WHT	899
a6	DC	60	WHT	1.240	b6	DC	60	WHT	1.228	c6	DC	60	WHT	889	d6	DC	40	WHT	779	br6	DC	40	WHT	787
a7	DC	60	WHT	1.382	b7	DC	60	WHT	1.361	c7	DC	60	WHT	1.071						br7	DC	40	WHT	474
a8	DC	60	WHT	1.340	b8	DC	60	WHT	1.326	c8	DC	60	WHT	1.059						br8	DC	40	WHT	485
a9	DC	60	WHT	1.345	b9	DC	60	WHT	1.332	c9	DC	60	WHT	1.103						br9	DC	40	WHT	585
a10	DC	60	WHT	1.057	b10	DC	60	WHT	993	c10	DC	60	WHT	1.017						br10	DC	40	WHT	543
a11	DC	60	WHT	1.161	b11	DC	60	WHT	1.150	c11	DC	60	WHT	1.178										
2A1	A-8000/U	190	NATURAL	1.521	2B1	A-8000/U	190	NATURAL	1.499	2C1	A-8000/U	190	NATURAL	1.105	2D1	DC	60	WHT	253	2BR1	TNL	80	RED	1.159
2A2	A-8000/U	190	NATURAL	1.462	2B2	A-8000/U	190	NATURAL	1.443	2C2	A-8000/U	190	NATURAL	1.050	2D2	DC	60	WHT	256	2BR2	TNL	80	RED	646
2A3	A-8000/U	190	NATURAL	1.285	2B3	A-8000/U	130	NATURAL	1.261	2C3	A-8000/U	130	NATURAL	990	2D3	DC	60	WHT	199	2BR3	TNL	80	RED	971
2A4	A-8000/U	130	NATURAL	1.063	2B4	A-8000/U	130	NATURAL	1.060	2C4	A-8000/U	130	NATURAL	735						2BR4	TNL	80	RED	466
2A5	A-8000/U	70	NATURAL	275															2BR5	TNL	80	RED	411	
3A1	A-8000/U	360	NATURAL	3.160	3B1	A-8000/U	360	NATURAL	3.119	3C1	A-8000/U	230	NATURAL	3.921						3BR1	TNL	80	RED	2.675
3A2	A-8000/U	230	NATURAL	3.352	3B2	A-8000/U	230	NATURAL	3.336	3C2	A-8000/U	230	NATURAL	4.002						3BR2	TNL	80	RED	820
																			4BR1	TNL	80	RED	2.300	
					stab	A-8000/U	70	NATURAL	3.211															
					stab2	TNL	80	RED	1.000										BR-MAIN	TNL	280	RED	2.271	
																			POINT:				2.071	



DONNÉES SUSPENTES

IKUMA					23																			
REF.	MAT.	KG	COLOR	m/m	REF.	MAT.	KG	COLOR	m/m	REF.	MAT.	KG	COLOR	m/m	REF.	MAT.	KG	COLOR	m/m	REF.	MAT.	KG	COLOR	m/m
A					B					C					D					BRAKE				
a1	DC	100	WHT	1.604	b1	DC	100	WHT	1.579	c1	DC	60	WHT	1.262	d1	DC	40	WHT	1.073	br1	DC	40	WHT	1.117
a2	DC	100	WHT	1.484	b2	DC	100	WHT	1.461	c2	DC	60	WHT	1.103	d2	DC	40	WHT	925	br2	DC	40	WHT	671
a3	DC	100	WHT	1.491	b3	DC	100	WHT	1.469	c3	DC	60	WHT	1.121	d3	DC	40	WHT	936	br3	DC	40	WHT	977
a4	DC	100	WHT	1.524	b4	DC	100	WHT	1.506	c4	DC	60	WHT	1.219	d4	DC	40	WHT	1.021	br4	DC	40	WHT	1.014
a5	DC	100	WHT	1.417	b5	DC	100	WHT	1.392	c5	DC	60	WHT	1.067	d5	DC	40	WHT	948	br5	DC	40	WHT	941
a6	DC	60	WHT	1.298	b6	DC	60	WHT	1.285	c6	DC	60	WHT	931	d6	DC	40	WHT	816	br6	DC	40	WHT	824
a7	DC	60	WHT	1.446	b7	DC	60	WHT	1.424	c7	DC	60	WHT	1.121						br7	DC	40	WHT	496
a8	DC	60	WHT	1.403	b8	DC	60	WHT	1.387	c8	DC	60	WHT	1.108						br8	DC	40	WHT	508
a9	DC	60	WHT	1.408	b9	DC	60	WHT	1.394	c9	DC	60	WHT	1.155						br9	DC	40	WHT	612
a10	DC	60	WHT	1.106	b10	DC	60	WHT	1.039	c10	DC	60	WHT	1.065						br10	DC	40	WHT	570
a11	DC	60	WHT	1.214	b11	DC	60	WHT	1.203	c11	DC	60	WHT	1.233										
2A1	A-8000/U	190	NATURAL	1.588	2B1	A-8000/U	190	NATURAL	1.559	2C1	A-8000/U	190	NATURAL	1.149	2D1	DC	60	WHT	265	2BR1	TNL	80	RED	1.211
2A2	A-8000/U	190	NATURAL	1.533	2B2	A-8000/U	190	NATURAL	1.513	2C2	A-8000/U	190	NATURAL	1.101	2D2	DC	60	WHT	270	2BR2	TNL	80	RED	678
2A3	A-8000/U	190	NATURAL	1.344	2B3	A-8000/U	130	NATURAL	1.319	2C3	A-8000/U	130	NATURAL	1.036	2D3	DC	60	WHT	209	2BR3	TNL	80	RED	1.016
2A4	A-8000/U	130	NATURAL	1.113	2B4	A-8000/U	130	NATURAL	1.110	2C4	A-8000/U	130	NATURAL	770						2BR4	TNL	80	RED	487
2A5	A-8000/U	70	NATURAL	288															2BR5	TNL	80	RED	431	
3A1	A-8000/U	360	NATURAL	3.331	3B1	A-8000/U	360	NATURAL	3.289	3C1	A-8000/U	230	NATURAL	4.127						3BR1	TNL	80	RED	2.799
3A2	A-8000/U	230	NATURAL	3.537	3B2	A-8000/U	230	NATURAL	3.520	3C2	A-8000/U	230	NATURAL	4.216						3BR2	TNL	80	RED	859
					stab	A-8000/U	70	NATURAL	3.435										4BR1	TNL	80	RED	2.410	
					stab2	TNL	80	RED	1.000										BR-MAIN	TNL	280	RED	2.381	
																			POINT:				2.181	



DONNÉES SUSPENTES

IKUMA					25																			
REF.	MAT.	KG	COLOR	m/m	REF.	MAT.	KG	COLOR	m/m	REF.	MAT.	KG	COLOR	m/m	REF.	MAT.	KG	COLOR	m/m	REF.	MAT.	KG	COLOR	m/m
A					B					C					D					BRAKE				
a1	DC	100	WHT	1.655	b1	DC	100	WHT	1.630	c1	DC	60	WHT	1.301	d1	DC	40	WHT	1.107	br1	DC	40	WHT	1.153
a2	DC	100	WHT	1.533	b2	DC	100	WHT	1.509	c2	DC	60	WHT	1.138	d2	DC	40	WHT	955	br2	DC	40	WHT	693
a3	DC	100	WHT	1.539	b3	DC	100	WHT	1.515	c3	DC	60	WHT	1.157	d3	DC	40	WHT	966	br3	DC	40	WHT	1.008
a4	DC	100	WHT	1.573	b4	DC	100	WHT	1.555	c4	DC	60	WHT	1.258	d4	DC	40	WHT	1.054	br4	DC	40	WHT	1.047
a5	DC	100	WHT	1.462	b5	DC	100	WHT	1.437	c5	DC	60	WHT	1.101	d5	DC	40	WHT	979	br5	DC	40	WHT	971
a6	DC	60	WHT	1.340	b6	DC	60	WHT	1.327	c6	DC	60	WHT	961	d6	DC	40	WHT	842	br6	DC	40	WHT	851
a7	DC	60	WHT	1.493	b7	DC	60	WHT	1.470	c7	DC	60	WHT	1.157						br7	DC	40	WHT	511
a8	DC	60	WHT	1.448	b8	DC	60	WHT	1.432	c8	DC	60	WHT	1.144						br8	DC	40	WHT	524
a9	DC	60	WHT	1.453	b9	DC	60	WHT	1.439	c9	DC	60	WHT	1.192						br9	DC	40	WHT	631
a10	DC	60	WHT	1.142	b10	DC	60	WHT	1.072	c10	DC	60	WHT	1.099						br10	DC	40	WHT	589
a11	DC	60	WHT	1.253	b11	DC	60	WHT	1.241	c11	DC	60	WHT	1.272										
2A1	A-8000/U	190	NATURAL	1.639	2B1	A-8000/U	190	NATURAL	1.616	2C1	A-8000/U	190	NATURAL	1.194	2D1	DC	60	WHT	279	2BR1	TNL	80	RED	1.249
2A2	A-8000/U	190	NATURAL	1.583	2B2	A-8000/U	190	NATURAL	1.563	2C2	A-8000/U	190	NATURAL	1.138	2D2	DC	60	WHT	285	2BR2	TNL	80	RED	701
2A3	A-8000/U	190	NATURAL	1.387	2B3	A-8000/U	130	NATURAL	1.361	2C3	A-8000/U	130	NATURAL	1.069	2D3	DC	60	WHT	221	2BR3	TNL	80	RED	1.048
2A4	A-8000/U	130	NATURAL	1.149	2B4	A-8000/U	130	NATURAL	1.146	2C4	A-8000/U	130	NATURAL	795						2BR4	TNL	80	RED	502
2A5	A-8000/U	70	NATURAL	297															2BR5	TNL	80	RED	445	
3A1	A-8000/U	360	NATURAL	3.455	3B1	A-8000/U	360	NATURAL	3.411	3C1	A-8000/U	230	NATURAL	4.277						3BR1	TNL	80	RED	2.889
3A2	A-8000/U	230	NATURAL	3.670	3B2	A-8000/U	230	NATURAL	3.653	3C2	A-8000/U	230	NATURAL	4.371						3BR2	TNL	80	RED	887
					stab	A-8000/U	70	NATURAL	3.582										4BR1	TNL	80	RED	2.489	
					stab2	TNL	80	RED	1.000										BR-MAIN	TNL	280	RED	2.468	
																			POINT:				2.268	

DONNÉES SUSPENTES

IKUMA					27																			
REF.	MAT.	KG	COLOR	m/m	REF.	MAT.	KG	COLOR	m/m	REF.	MAT.	KG	COLOR	m/m	REF.	MAT.	KG	COLOR	m/m	REF.	MAT.	KG	COLOR	m/m
A					B					C					D					BRAKE				
a1	DC	100	WHT	1.721	b1	DC	100	WHT	1.695	c1	DC	60	WHT	1.352	d1	DC	40	WHT	1.151	br1	DC	40	WHT	1.199
a2	DC	100	WHT	1.595	b2	DC	100	WHT	1.571	c2	DC	60	WHT	1.183	d2	DC	40	WHT	994	br2	DC	40	WHT	721
a3	DC	100	WHT	1.599	b3	DC	100	WHT	1.575	c3	DC	60	WHT	1.202	d3	DC	40	WHT	1.004	br3	DC	40	WHT	1.048
a4	DC	100	WHT	1.636	b4	DC	100	WHT	1.618	c4	DC	60	WHT	1.309	d4	DC	40	WHT	1.096	br4	DC	40	WHT	1.089
a5	DC	100	WHT	1.521	b5	DC	100	WHT	1.494	c5	DC	60	WHT	1.145	d5	DC	40	WHT	1.018	br5	DC	40	WHT	1.010
a6	DC	60	WHT	1.394	b6	DC	60	WHT	1.380	c6	DC	60	WHT	1.000	d6	DC	40	WHT	876	br6	DC	40	WHT	886
a7	DC	60	WHT	1.552	b7	DC	60	WHT	1.528	c7	DC	60	WHT	1.203						br7	DC	40	WHT	532
a8	DC	60	WHT	1.506	b8	DC	60	WHT	1.489	c8	DC	60	WHT	1.190						br8	DC	40	WHT	546
a9	DC	60	WHT	1.512	b9	DC	60	WHT	1.497	c9	DC	60	WHT	1.240						br9	DC	40	WHT	656
a10	DC	60	WHT	1.187	b10	DC	60	WHT	1.115	c10	DC	60	WHT	1.143						br10	DC	40	WHT	614
a11	DC	60	WHT	1.303	b11	DC	60	WHT	1.291	c11	DC	60	WHT	1.323										
2A1	A-8000/U	190	NATURAL	1.703	2B1	A-8000/U	190	NATURAL	1.679	2C1	A-8000/U	190	NATURAL	1.241	2D1	DC	60	WHT	285	2BR1	TNL	80	RED	1.298
2A2	A-8000/U	190	NATURAL	1.649	2B2	A-8000/U	190	NATURAL	1.627	2C2	A-8000/U	190	NATURAL	1.185	2D2	DC	60	WHT	292	2BR2	TNL	80	RED	730
2A3	A-8000/U	190	NATURAL	1.442	2B3	A-8000/U	130	NATURAL	1.415	2C3	A-8000/U	130	NATURAL	1.111	2D3	DC	60	WHT	225	2BR3	TNL	80	RED	1.089
2A4	A-8000/U	130	NATURAL	1.196	2B4	A-8000/U	130	NATURAL	1.192	2C4	A-8000/U	130	NATURAL	827						2BR4	TNL	80	RED	522
2A5	A-8000/U	70	NATURAL	309															2BR5	TNL	80	RED	463	
3A1	A-8000/U	360	NATURAL	3.615	3B1	A-8000/U	360	NATURAL	3.569	3C1	A-8000/U	230	NATURAL	4.477						3BR1	TNL	80	RED	3.004
3A2	A-8000/U	230	NATURAL	3.842	3B2	A-8000/U	230	NATURAL	3.824	3C2	A-8000/U	230	NATURAL	4.579						3BR2	TNL	80	RED	924
					stab	A-8000/U	70	NATURAL	3.790										4BR1	TNL	80	RED	2.591	
					stab2	TNL	80	RED	1.000										BR-MAIN	TNL	280	RED	2.579	
																			POINT:				2.379	

DONNÉES SUSPENTES

IKUMA					29																			
REF.	MAT.	KG	COLOR	m/m	REF.	MAT.	KG	COLOR	m/m	REF.	MAT.	KG	COLOR	m/m	REF.	MAT.	KG	COLOR	m/m	REF.	MAT.	KG	COLOR	m/m
A					B					C					D					BRAKE				
a1	DC	100	WHT	1.800	b1	DC	100	WHT	1.773	c1	DC	60	WHT	1.412	d1	DC	40	WHT	1.204	br1	DC	40	WHT	1.254
a2	DC	100	WHT	1.670	b2	DC	100	WHT	1.645	c2	DC	60	WHT	1.238	d2	DC	40	WHT	1.041	br2	DC	40	WHT	756
a3	DC	100	WHT	1.672	b3	DC	100	WHT	1.647	c3	DC	60	WHT	1.257	d3	DC	40	WHT	1.050	br3	DC	40	WHT	1.095
a4	DC	100	WHT	1.712	b4	DC	100	WHT	1.693	c4	DC	60	WHT	1.370	d4	DC	40	WHT	1.147	br4	DC	40	WHT	1.139
a5	DC	100	WHT	1.591	b5	DC	100	WHT	1.563	c5	DC	60	WHT	1.198	d5	DC	40	WHT	1.065	br5	DC	40	WHT	1.056
a6	DC	60	WHT	1.459	b6	DC	60	WHT	1.444	c6	DC	60	WHT	1.046	d6	DC	40	WHT	917	br6	DC	40	WHT	927
a7	DC	60	WHT	1.624	b7	DC	60	WHT	1.598	c7	DC	60	WHT	1.258						br7	DC	40	WHT	556
a8	DC	60	WHT	1.575	b8	DC	60	WHT	1.558	c8	DC	60	WHT	1.244						br8	DC	40	WHT	571
a9	DC	60	WHT	1.582	b9	DC	60	WHT	1.566	c9	DC	60	WHT	1.297						br9	DC	40	WHT	686
a10	DC	60	WHT	1.242	b10	DC	60	WHT	1.166	c10	DC	60	WHT	1.196						br10	DC	40	WHT	643
a11	DC	60	WHT	1.363	b11	DC	60	WHT	1.350	c11	DC	60	WHT	1.384										
2A1	A-8000/U	190	NATURAL	1.780	2B1	A-8000/U	190	NATURAL	1.754	2C1	A-8000/U	190	NATURAL	1.299	2D1	DC	60	WHT	299	2BR1	TNL	80	RED	1.357
2A2	A-8000/U	190	NATURAL	1.727	2B2	A-8000/U	190	NATURAL	1.705	2C2	A-8000/U	190	NATURAL	1.242	2D2	DC	60	WHT	307	2BR2	TNL	80	RED	765
2A3	A-8000/U	190	NATURAL	1.509	2B3	A-8000/U	130	NATURAL	1.480	2C3	A-8000/U	130	NATURAL	1.162	2D3	DC	60	WHT	235	2BR3	TNL	80	RED	1.139
2A4	A-8000/U	130	NATURAL	1.252	2B4	A-8000/U	130	NATURAL	1.248	2C4	A-8000/U	130	NATURAL	866						2BR4	TNL	80	RED	545
2A5	A-8000/U	70	NATURAL	323															2BR5	TNL	80	RED	485	
3A1	A-8000/U	360	NATURAL	3.806	3B1	A-8000/U	360	NATURAL	3.759	3C1	A-8000/U	230	NATURAL	4.698						3BR1	TNL	80	RED	3.141
3A2	A-8000/U	230	NATURAL	4.048	3B2	A-8000/U	230	NATURAL	4.029	3C2	A-8000/U	230	NATURAL	4.809						3BR2	TNL	80	RED	967
																			4BR1	TNL	80	RED	2.714	
					stab	A-8000/U	70	NATURAL	4.055															
					stab2	TNL	80	RED	1.000										BR-MAIN	TNL	280	RED	2.713	
																			POINT:				2.513	

NIVIUK IKUMA 21

LONGUEURS TOTALES m/m

	A	B	C	D	br
1	6213	6127	6233	6304	6972
2	6097	6012	6080	6161	6545
3	6048	5966	6044	6123	6326
4	6077	6001	6136	6203	6361
5	5991	5927	6011	6097	6241
6	5877	5824	5881	5971	6129
7	5797	5756	5808		6130
8	5755	5721	5796		6142
9	5760	5728	5841		6186
10	5535	5471	5496		6145
11	5364	5353	5381		

LONGUEURS DES ELEVATEURS m/m

	A	B'	B	C	
	480	480	480	480	NEUTRE
	360	380	400	480	ACCÉLÉRÉE

NIVIUK IKUMA 23

LONGUEURS TOTALES m/m

	A	B	C	D	br
1	6517	6427	6538	6614	7308
2	6397	6309	6379	6466	6862
3	6355	6270	6350	6435	6635
4	6388	6308	6448	6519	6672
5	6298	6231	6319	6409	6548
6	6180	6124	6183	6277	6431
7	6096	6054	6107		6433
8	6053	6017	6094		6445
9	6058	6024	6141		6492
10	5821	5754	5780		6450
11	5642	5630	5660		

LONGUEURS DES ELEVATEURS m/m

	A	B'	B	C	
	480	480	480	480	NEUTRE
	360	380	400	480	ACCÉLÉRÉE

NIVIUK IKUMA 25

LONGUEURS TOTALES m/m

	A	B	C	D	br
1	6750	6657	6771	6856	7558
2	6627	6536	6608	6704	7098
3	6577	6490	6571	6665	6865
4	6612	6529	6673	6753	6904
5	6520	6451	6541	6640	6776
6	6398	6341	6401	6503	6656
7	6312	6268	6323		6658
8	6267	6230	6310		6671
9	6273	6238	6358		6720
10	6013	5943	5970		6678
11	5827	5815	5846		

LONGUEURS DES ELEVATEURS m/m

	A	B'	B	C	
	480	480	480	480	NEUTRE
	360	380	400	480	ACCÉLÉRÉE

NIVIUK IKUMA 27

LONGUEURS TOTALES m/m

	A	B	C	D	br
1	7039	6943	7062	7146	7880
2	6913	6819	6893	6989	7403
3	6863	6772	6856	6950	7161
4	6900	6815	6962	7042	7202
5	6805	6733	6827	6924	7070
6	6679	6619	6681	6782	6946
7	6590	6544	6600		6948
8	6544	6505	6587		6962
9	6550	6513	6637		7013
10	6279	6206	6249		6971
11	6085	6073	6120		

LONGUEURS DES ELEVATEURS m/m

	A	B'	B	C	
	480	480	480	480	NEUTRE
	360	380	400	480	ACCÉLÉRÉE

LONGUEURS TOTALES m/m

	A	B	C	D	br
1	7386	7286	7409	7500	8266
2	7256	7157	7235	7337	7767
3	7205	7110	7197	7297	7515
4	7245	7156	7310	7395	7559
5	7147	7072	7169	7272	7422
6	7015	6953	7017	7123	7293
7	6923	6875	6933		7296
8	6875	6834	6919		7310
9	6881	6843	6972		7365
10	6612	6536	6566		7323
11	6410	6397	6431		

LONGUEURS DES ELEVATEURS m/m

	A	B'	B	C	
	480	480	480	480	NEUTRE
	360	380	400	480	ACCÉLÉRÉE

DONNÉES TECHNIQUES SUSPENTAGE

IKUMA

CODE MATERIAL		DC	DC	DC	TNL	TNL	A-8000/U	A-8000/U	A-8000/U	A-8000/U	A-8000/U	A-8000/U
CODE CHARGE		040	060	100	080	280	050	070	130	190	230	360
DIAMETRE EN m/m	Ø	0,5	0,6	0,8	1,1	1,8	0,5	0,7	0,9	1,1	1,1 X 1,4	1,4 X 1,9
MATERIEL AME		DYNEEMA	DYNEEMA	DYNEEMA	TECHNORA	TECHNORA	ARAMID	ARAMID	ARAMID	ARAMID	ARAMID	ARAMID
MATERIEL GAINE		NON	NON	NON	POLYESTER	POLYESTER	NON	NON	NON	NON	NON	NON
POIDS METRIQUE G/M	TOTAL	0,19	0,24	0,42	1,1	2,7	0,3	0,4	0,8	1,1	1,4	2,1
CHARGE DE RUPTURE	MINIMUM	40	60	100	80	280	50	70	130	190	230	360
	MAXIMUM	48	84	110	92	320	59	78	144	211	255	380
RESISTANCE APRES												
5,000 CYCLES	TEST EN	33	74	99	36,7	134,7	26	39	88	52	69	196,6
DE FLEXION												
ALLONGEMENT A	5 DAN EN %				0,3	0,2	0,4	0,5	0,4	0,4	0,3	0,2
	10 daN en %		0,43	0,36	0,5	0,3	0,7	0,7	0,6	0,6	0,5	0,3
	15 DAN EN %				0,7	0,4	1,1	1	0,8	0,7	0,6	0,4
	20 DAN EN %				1	0,4	1,5	1,3	0,9	0,9	0,7	0,5
	25 DAN EN %				1,3	0,5	1,9	1,5	1	1	0,8	0,6
	30 DAN EN %		1,2	1	2,3	0,9	3,3	2,8	1,8	1,6	1,3	
	75 DAN EN %				2,8	1,3		3,7	3,1	2,7	2,3	1,5
	100 DAN EN %					1,7				2,6	3,6	1,9
	125 daN en %					2				3,5	3,3	
	150 DAN EN %					2,3				4,3	3,6	2,6
	175 DAN EN %					2,7						
	200 DAN EN %					2,8						3,1
	250 DAN EN %											3,6
ALLONGEMENT A LA CHARGE DE RUPTURE %			3,2	3,4	3	4,1	3,8	3,9	4	4,4	4,4	

DONNÉES TECHNIQUES MAILLON

DESCRIPTION

MAILLON	DELTA
REF.	3.5
MATERIEL	STAINLESS STEEL
DIAMETRE	3 m/m
POIDS	5 G/PIECE

DONNÉES TECHNIQUES

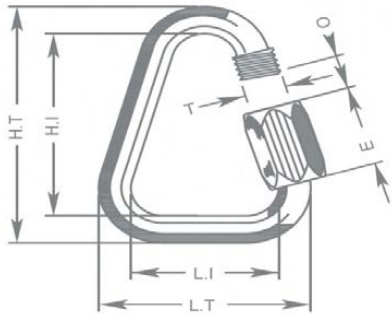

DIMENSIONS	m/m
L.T.	22
L.I.	14
H.T.	37
H.I.	29
O	5
E	12
T	4
CHARGE	KG
UTILE	110
RUPTURE	550

MATERIEL

AISI 304 ACIER INOXYDABLE STANDARD

UNE FERMETURE MANUELLE ET TOTALMENT VISSÉE POUR

GARANTIR UNE SÉCURITÉ MAXIMALE (LA SPIRALE EN MÉTAL NE DOIT PLUS APPARAÎTRE)

CONTROLE SYSTEMATIQUE DES MAILLONS RAPIDES AVANT CHAQUE VOL

DONNÉES TECHNIQUES POULIE

DESCRIPTION

POULIE	20 m/m
CODE	ID018041
MATERIEL	STAINLESS STEEL
	NYLON
	CARBON ACETAL
COUSSINET	DELRIN®
POIDS	14 G/PIECE

DONNÉES TECHNIQUES

DIMENSIONS	m/m
L.T.	20
H.T.	33
Ø	5 max
CHARGE	KG
UTILE	200
RUPTURE	400

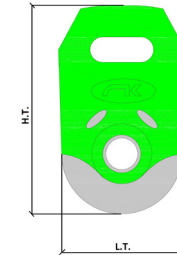

DONNÉES TECHNIQUES FIL**CARACTERISTIQUES DU FIL DE COUTURE**

NOM	SERAFIL
N° DE REFERENCE	60
MATERIEL	POLYESTER
FINITION	SILK
DENSITE LINEAIRE	NM 61 / 3 (DTEX 163 * 3)
CHARGE DE RUPTURE	3,000 CN
ALLONGEMENT	17,00%

PROPIETIES SERAFIL

SOLIDITE A LA LUMIERE ARTIFICIELLE	ISO 105 B02 > 5 - 6
SOLIDITE A LA SUEUR	ISO 105 E04 > 4
SOLIDITE AU LAVAGE	ISO 105 C04 > 3
SOLIDITE AU FROTTEMENT A SEC	ISO 105 X12 > 4
SOLIDITE AU LAVAGE EN SECHERESSE	ISO 105 D01 > 3 - 4

DEPERLANT	WR
-----------	----

CARACTERISTIQUES DES ELEVATEURS

NOM	COATS BONDED C.F.P.
N° DE REFERENCE	V138
MATERIEL	POLYESTER
FINITION	SILK
CHARGE DE RUPTURE	9,5 KG
ALLONGEMENT	19%

DONNÉES TECHNIQUES ÉLÉVATEURS**ÉLÉVATEURS**

REFERENCE	3455
MATERIEL	POLYESTER & TECHNORA
LARGEUR	12 M/M
EPAISSEUR	0,9 M/M
CHARGE DE RUPTURE	1.078 DAN
ALLONGEMENT	MAX. 11%
POIDS	9,1 G* L.M.
COULEUR	NOIR

INDICATEUR DE COULEUR

REFERENCE	IC-G 1-2
MATERIEL	POLYESTER
LARGEUR	70 M/M
EPAISSEUR	0,80 M/M
CHARGE DE RUPTURE	130 DN
ALLONGEMENT	35 %
POIDS	32 G * L.M.
COULEUR	VERT

POINT D'ATTACHE

REFERENCE	LKI - 10
MATERIEL	NYLON
LARGEUR	10 M/M
CHARGE DE RUPTURE	84 KG
ALLONGEMENT	30 %
POIDS	5,5 G/M
COULEUR	BLANC

