

DONNEES
TECHNIQUES
LINK



DONNEES TECHNIQUES

LINK			23	25	27	29
ALVEOLES	NOMBRE		50	50	50	50
	FERME		6	6	6	6
	CAISSONS		27	27	27	27
A PLAT	SURFACE	M2	23	25	27	29,5
	ENVERGURE	M	11,04	11,51	11,96	12,5
	ALLONGEMENT		5,3	5,3	5,3	5,3
PROJETEE	SURFACE	M2	19,55	21,23	22,9	24,99
	ENVERGURE		8,65	9,29	9,32	9,76
	ALLONGEMENT		3,82	3,82	3,82	3,82
APLATISSEMENT		%	15	15	15	15
CORDE	MAXIMUM		2,56	2,67	2,77	2,9
	MINIMUM		0,6	0,62	0,65	0,69
	MOYENNE		2,08	2,17	2,25	2,34
SUSPENTES	TOTALES	M	276	294	306	317
	HAUTEUR	M	6,87	7,11	7,41	7,72
	NOMBRE		218	218	218	218
	REPARTITION		3/3/4/2	3/3/4/2	3/3/4/2	3/3/4/2
ELEVATEURS	NOMBRE	4	A/B/C/D	A/B/C/D	A/B/C/D	A/B/C/D
	TRIMS	m/m	90	90	90	90
	ACCELERATEUR	m/m	100	100	100	100
POIDS TOTAL	MINIMUM	KG	65	80	95	110
EN VOL	MAXIMUM	KG	120	140	160	180
POIDS DE L'AILE		KG	5,2	5,5	5,8	6,1
HOMOLOGATION		EN/LTF	B	B	B	B

MATERIAUX

VOILERIE	MATERIAUX	FABRICANT
EXTRADOS	SKYTEX 40 9017 E77	PORCHER IND (FRANCE)
INTRADOS	N 20D MF	DOMINICO TEX CO
PROFIL	30D FM	DOMINICO TEX CO
DIAGONALES	30D FM	DOMINICO TEX CO
POINT D'ATTACHE	LKI - 10	KOLON IND. (KOREA)
RENFORT DU POINT D'ATTACHE	W-420	D-P (GERMANY)
RENFORT DU BORD DE FUITE	MYLAR	D-P (GERMANY)
RENFORT CLOISONS	W-420	D-P (GERMANY)
FIL	SERAFIL 60	AMAN (GERMANY)

SUSPENTAGE	MATERIAUX	FABRICANT
CASCADES SUPERIEURES	TNL - 080	EDELRID (GERMANY)
CASCADES INTERMEDIAIRES	TNL - 080	TEIJIM LIMITED (JAPAN)
CASCADES INTERMEDIAIRES	TNL - 140	TEIJIM LIMITED (JAPAN)
CASCADES PRINCIPALES	TNL - 280	TEIJIM LIMITED (JAPAN)
CASCADES PRINCIPALES	TNL - 220	TEIJIM LIMITED (JAPAN)
CASCADES PRINCIPALES	TNL - 140	TEIJIM LIMITED (JAPAN)
CASCADES PRINCIPALES FREIN	TNL - 400	TEIJIM LIMITED (JAPAN)
FIL	SERAFIL 60	AMAN (GERMANY)

ELEVATEURS	MATERIAUX	FABRICANT
SANGLES	G-R 22	TECNI SANGLES (FRANCE)
INDICATEUR DE COULEUR	PAD	TECNI SANGLES (FRANCE)
FIL	V138	COATS (ENGLAND)
MAILLONS	MRI4	ANSUNG PRECISION (KOREA)
POULIE	224	HARKEN (USA)

PLAN DE SUSPENTAGE

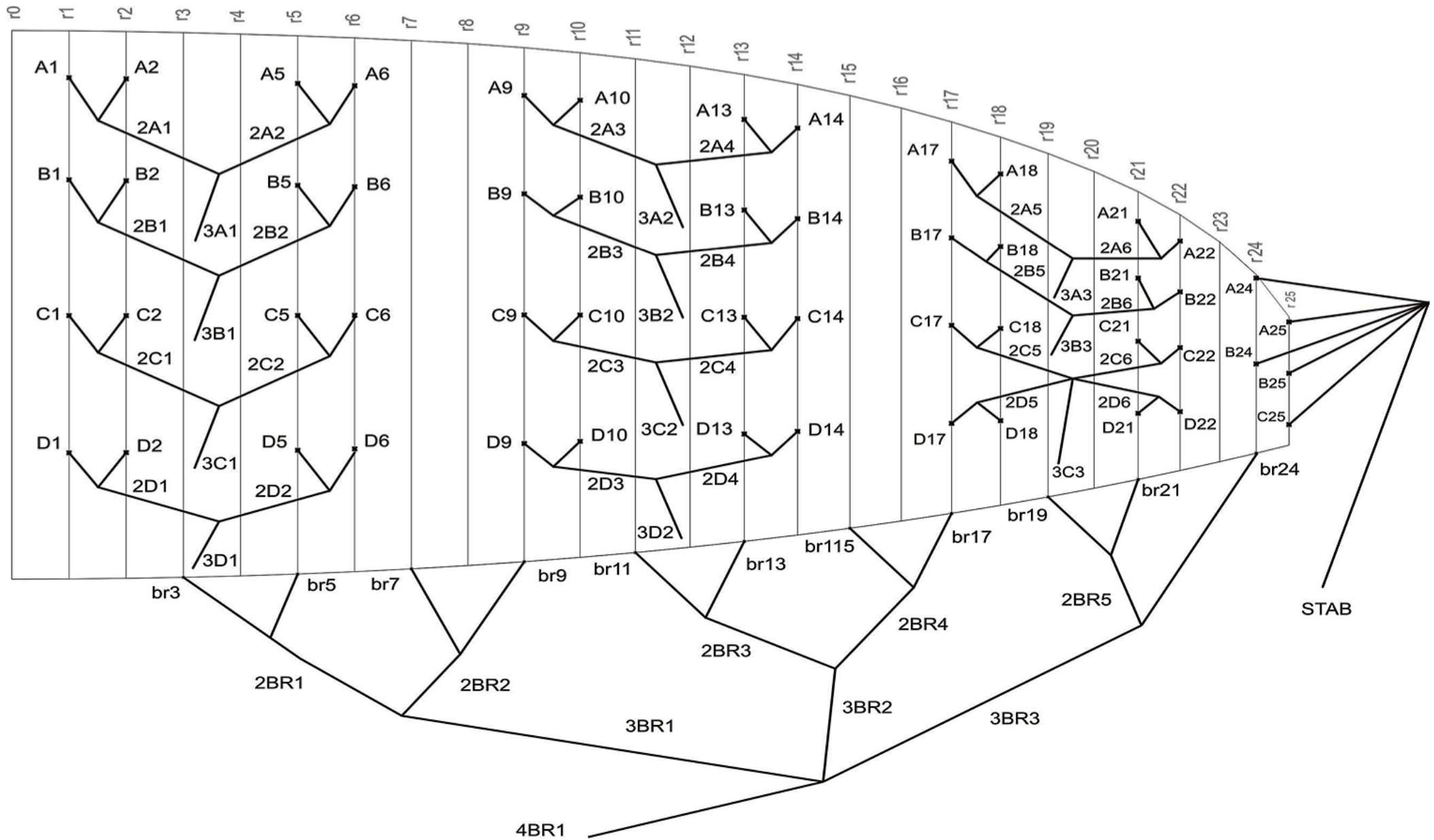

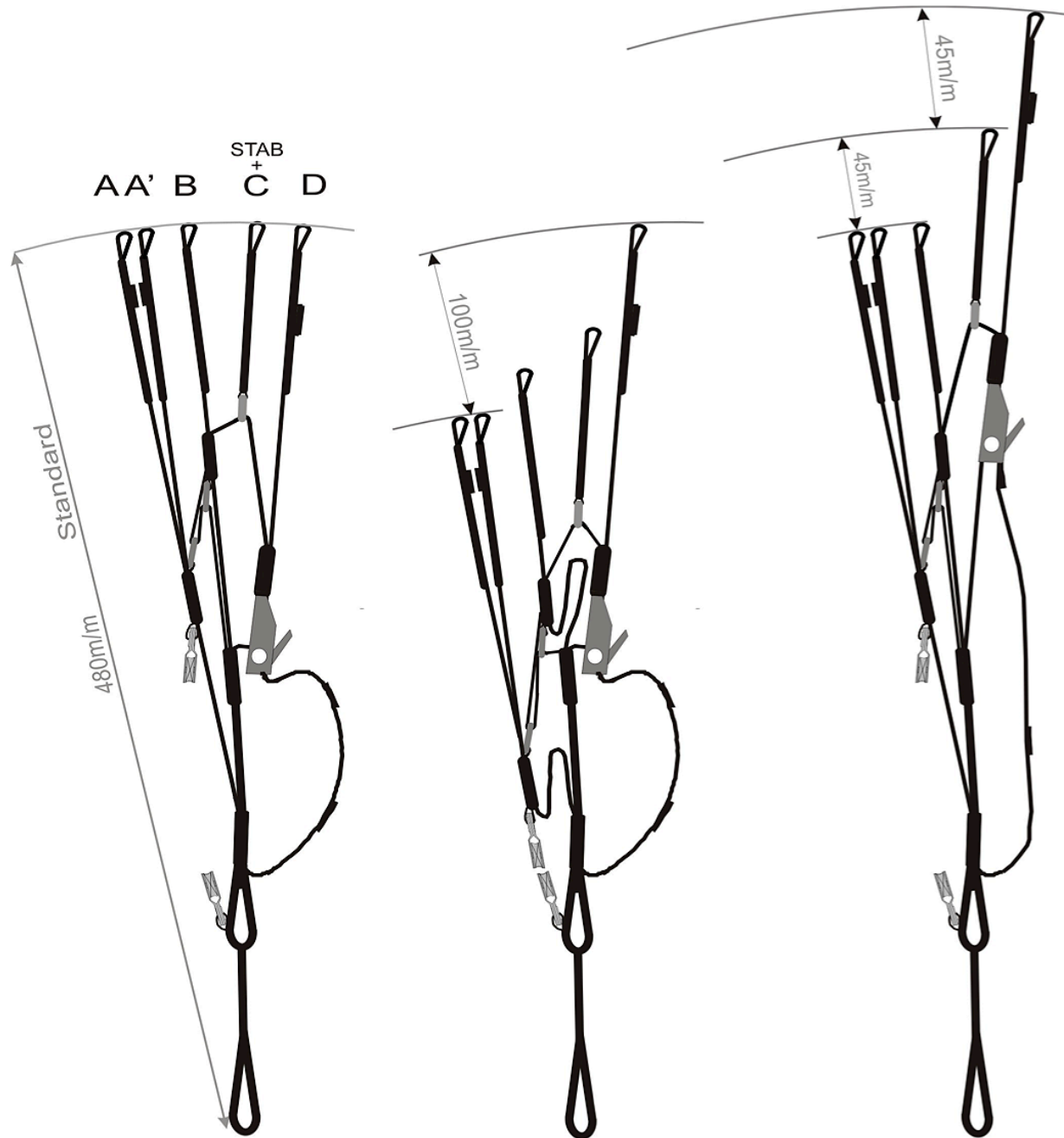

DONNEES TECHNIQUES DES COULEURS

SAPPHIRE	1	ROYAL BLUE	MAIN TOP	REF: 317
	2	LIMA	HORNS	REF: 500
	3	BLACK	SHADOW	REF: 102
	4	ROYAL BLUE	MAIN BOTTOM	REF: 317
	5	BLACK	LEADING SHADOW	REF: 102



MONARCA	1	ORANGE	MAIN TOP	REF: 744
	2	GOLD	HORNS	REF: 939
	3	BLACK	SHADOW	REF: 102
	4	ORANGE	MAIN BOTTOM	REF: 744
	5	BLACK	LEADING SHADOW	REF: 102



KAKI	1	LIMA	MAIN TOP	REF: 500
	2	DRAGON RED	HORNS	REF: 636
	3	BLACK	SHADOW	REF: 102
	4	LIMA	MAIN BOTTOM	REF: 500
	5	BLACK	LEADING SHADOW	REF: 102

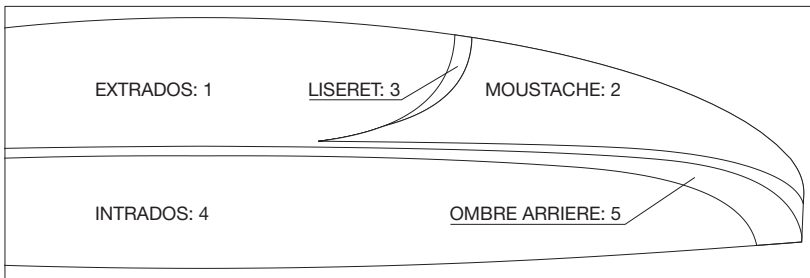

DONNEES TECHNIQUES CHARGE ALAIRE

LINK	23		25		27		29				
	P.T.V.	KG/M2	P.T.V.	KG/M2	P.T.V.	KG/M2	P.T.V.	KG/M2			
65	=	2,83	80	=	3,20	95	=	3,52	110	=	3,73
66	=	2,87	81	=	3,24	96	=	3,56	111	=	3,76
67	=	2,91	82	=	3,28	97	=	3,59	112	=	3,80
68	=	2,96	83	=	3,32	98	=	3,63	113	=	3,83
69	=	3,00	84	=	3,36	99	=	3,67	114	=	3,86
70	=	3,04	85	=	3,40	100	=	3,70	115	=	3,90
71	=	3,09	86	=	3,44	101	=	3,74	116	=	3,93
72	=	3,13	87	=	3,48	102	=	3,78	117	=	3,97
73	=	3,17	88	=	3,52	103	=	3,81	118	=	4,00
74	=	3,22	89	=	3,56	104	=	3,85	119	=	4,03
75	=	3,26	90	=	3,60	105	=	3,89	120	=	4,07
76	=	3,30	91	=	3,64	106	=	3,93	121	=	4,10
77	=	3,35	92	=	3,68	107	=	3,96	122	=	4,14
78	=	3,39	93	=	3,72	108	=	4,00	123	=	4,17
79	=	3,43	94	=	3,76	109	=	4,04	124	=	4,20
80	=	3,48	95	=	3,80	110	=	4,07	125	=	4,24
81	=	3,52	96	=	3,84	111	=	4,11	126	=	4,27
82	=	3,57	97	=	3,88	112	=	4,15	127	=	4,31
83	=	3,61	98	=	3,92	113	=	4,19	128	=	4,34
84	=	3,65	99	=	3,96	114	=	4,22	129	=	4,37
85	=	3,70	100	=	4,00	115	=	4,26	130	=	4,41

DONNEES SUSPENTES

LINK		23												
REF.	CODE	m/m	REF.	CODE	m/m	REF.	CODE	m/m	REF.	CODE	m/m	REF.	CODE	m/m
A			B			C			D			BRAKE		
A1	TNL-080-green	335	B1	TNL-080-blue	330	C1	TNL-080-blue	335	D1	TNL-080-blue	340	br3	TNL-080-red	985
A2	TNL-080-green	295	B2	TNL-080-blue	295	C2	TNL-080-blue	290	D2	TNL-080-blue	290	br5	TNL-080-red	790
A5	TNL-080-green	305	B5	TNL-080-blue	305	C5	TNL-080-blue	300	D5	TNL-080-blue	300	br7	TNL-080-red	945
A6	TNL-080-green	325	B6	TNL-080-blue	325	C6	TNL-080-blue	325	D6	TNL-080-blue	335	br9	TNL-080-red	905
A9	TNL-080-green	325	B9	TNL-080-blue	325	C9	TNL-080-blue	325	D9	TNL-080-blue	330	br11	TNL-080-red	900
A10	TNL-080-green	290	B10	TNL-080-blue	290	C10	TNL-080-blue	285	D10	TNL-080-blue	285	br13	TNL-080-red	820
A13	TNL-080-green	290	B13	TNL-080-blue	280	C13	TNL-080-blue	280	D13	TNL-080-blue	280	br15	TNL-080-red	775
A14	TNL-080-green	305	B14	TNL-080-blue	305	C14	TNL-080-blue	305	D14	TNL-080-blue	310	br17	TNL-080-red	830
A14	TNL-080-green	330	B17	TNL-080-blue	320	C17	TNL-080-blue	315	D17	TNL-080-blue	320	br19	TNL-080-red	740
A18	TNL-080-green	280	B18	TNL-080-blue	270	C18	TNL-080-blue	265	D18	TNL-080-blue	270	br21	TNL-080-red	670
A21	TNL-080-green	300	B21	TNL-080-blue	280	C21	TNL-080-blue	270	D21	TNL-080-blue	270	br24	TNL-080-red	1345
A22	TNL-080-green	275	B22	TNL-080-blue	260	C22	TNL-080-blue	240	D22	TNL-080-blue	235			
A24	TNL-080-red	2040	B24	TNL-080-red	2010									
A25	TNL-080-red	1925	B25	TNL-080-red	1930	C25	TNL-080-red	1965						
2A1	TNL-140-green	2060	2B1	TNL-140-blue	2050	2C1	TNL-140-blue	1880	2D1	TNL-080-blue	1615	2BR1	TNL-080-red	1215
2A2	TNL-140-green	2015	2B2	TNL-140-blue	2005	2C2	TNL-140-blue	1840	2D2	TNL-080-blue	1575	2BR2	TNL-080-red	915
2A3	TNL-140-green	1975	2B3	TNL-140-blue	1950	2C3	TNL-140-blue	1780	2D3	TNL-080-blue	1535	2BR3	TNL-080-red	950
2A4	TNL-140-green	1950	2B4	TNL-140-blue	1940	2C4	TNL-140-blue	1770	2D4	TNL-080-blue	1510	2BR4	TNL-080-red	990
2A5	TNL-140-green	1685	2B5	TNL-140-blue	1605	2C5	TNL-080-blue	1655	2D5	TNL-080-blue	1715	2BR5	TNL-080-red	840
2A6	TNL-140-green	1500	2B6	TNL-140-blue	1445	2C6	TNL-080-blue	1490	2D6	TNL-080-blue	1540			
3A1	TNL-280-green	4010	3B1	TNL-280-blue	3945	3C1	TNL-280-blue	4130	3D1	TNL-220-blue	4500	3br1	TNL-080-red	2695
3A2	TNL-220-green	4000	3B2	TNL-220-blue	3960	3C2	TNL-220-blue	4140	3D2	TNL-220-blue	4485	3br2	TNL-080-red	2550
3A3	TNL-220-green	4090	3B3	TNL-220-blue	4145	3C3	TNL-140-blue	4120				3br3	TNL-080-red	2655
						STAB	TNL-080-red	3565				4br1	TNL-280-red	2295

Point a: 2095

DONNEES SUSPENTES

LINK			25											
REF.	CODE	m/m	REF.	CODE	m/m	REF.	CODE	m/m	REF.	CODE	m/m	REF.	CODE	m/m
A			B			C			D			BRAKE		
A1	TNL-080-green	350	B1	TNL-080-blue	345	C1	TNL-080-blue	350	D1	TNL-080-blue	355	br3	TNL-080-red	1025
A2	TNL-080-green	305	B2	TNL-080-blue	305	C2	TNL-080-blue	305	D2	TNL-080-blue	300	br5	TNL-080-red	825
A5	TNL-080-green	320	B5	TNL-080-blue	315	C5	TNL-080-blue	315	D5	TNL-080-blue	315	br7	TNL-080-red	985
A6	TNL-080-green	340	B6	TNL-080-blue	340	C6	TNL-080-blue	340	D6	TNL-080-blue	345	br9	TNL-080-red	945
A9	TNL-080-green	340	B9	TNL-080-blue	335	C9	TNL-080-blue	340	D9	TNL-080-blue	345	br11	TNL-080-red	935
A10	TNL-080-green	305	B10	TNL-080-blue	300	C10	TNL-080-blue	300	D10	TNL-080-blue	295	br13	TNL-080-red	855
A13	TNL-080-green	300	B13	TNL-080-blue	295	C13	TNL-080-blue	290	D13	TNL-080-blue	290	br15	TNL-080-red	805
A14	TNL-080-green	320	B14	TNL-080-blue	315	C14	TNL-080-blue	315	D14	TNL-080-blue	325	br17	TNL-080-red	865
A14	TNL-080-green	345	B17	TNL-080-blue	330	C17	TNL-080-blue	330	D17	TNL-080-blue	330	br19	TNL-080-red	770
A18	TNL-080-green	290	B18	TNL-080-blue	285	C18	TNL-080-blue	280	D18	TNL-080-blue	280	br21	TNL-080-red	700
A21	TNL-080-green	315	B21	TNL-080-blue	295	C21	TNL-080-blue	280	D21	TNL-080-blue	280	br24	TNL-080-red	1405
A22	TNL-080-green	290	B22	TNL-080-blue	270	C22	TNL-080-blue	250	D22	TNL-080-blue	245			
A24	TNL-080-red	2125	B24	TNL-080-red	2095									
A25	TNL-080-red	2005	B25	TNL-080-red	2015	C25	TNL-080-red	2050						
2A1	TNL-140-green	2150	2B1	TNL-140-blue	2135	2C1	TNL-140-blue	1960	2D1	TNL-080-blue	1685	2BR1	TNL-080-red	1270
2A2	TNL-140-green	2100	2B2	TNL-140-blue	2090	2C2	TNL-140-blue	1920	2D2	TNL-080-blue	1640	2BR2	TNL-080-red	955
2A3	TNL-140-green	2060	2B3	TNL-140-blue	2035	2C3	TNL-140-blue	1860	2D3	TNL-080-blue	1600	2BR3	TNL-080-red	990
2A4	TNL-140-green	2030	2B4	TNL-140-blue	2020	2C4	TNL-140-blue	1845	2D4	TNL-080-blue	1575	2BR4	TNL-080-red	1030
2A5	TNL-140-green	1755	2B5	TNL-140-blue	1670	2C5	TNL-080-blue	1725	2D5	TNL-080-blue	1790	2BR5	TNL-080-red	875
2A6	TNL-140-green	1560	2B6	TNL-140-blue	1505	2C6	TNL-080-blue	1555	2D6	TNL-080-blue	1605			
3A1	TNL-280-green	4180	3B1	TNL-280-blue	4115	3C1	TNL-280-blue	4305	3D1	TNL-220-blue	4695	3br1	TNL-080-red	2810
3A2	TNL-220-green	4170	3B2	TNL-220-blue	4125	3C2	TNL-220-blue	4320	3D2	TNL-220-blue	4675	3br2	TNL-080-red	2660
3A3	TNL-220-green	4257	3B3	TNL-220-blue	4320	3C3	TNL-140-blue	4295				3br3	TNL-080-red	2765
						STAB	TNL-080-red	3695				4br1	TNL-280-red	2385

Point a: 2185

DONNEES SUSPENTES

LINK 27

REF.	CODE	m/m	REF.	CODE	m/m	REF.	CODE	m/m	REF.	CODE	m/m	REF.	CODE	m/m
A			B			C			D			BRAKE		
A1	TNL-080-green	360	B1	TNL-080-blue	360	C1	TNL-080-blue	360	D1	TNL-080-blue	370	br3	TNL-080-red	1065
A2	TNL-080-green	320	B2	TNL-080-blue	320	C2	TNL-080-blue	315	D2	TNL-080-blue	315	br5	TNL-080-red	855
A5	TNL-080-green	330	B5	TNL-080-blue	330	C5	TNL-080-blue	325	D5	TNL-080-blue	325	br7	TNL-080-red	1025
A6	TNL-080-green	355	B6	TNL-080-blue	350	C6	TNL-080-blue	355	D6	TNL-080-blue	360	br9	TNL-080-red	980
A9	TNL-080-green	355	B9	TNL-080-blue	350	C9	TNL-080-blue	355	D9	TNL-080-blue	360	br11	TNL-080-red	975
A10	TNL-080-green	315	B10	TNL-080-blue	315	C10	TNL-080-blue	310	D10	TNL-080-blue	305	br13	TNL-080-red	890
A13	TNL-080-green	310	B13	TNL-080-blue	305	C13	TNL-080-blue	300	D13	TNL-080-blue	300	br15	TNL-080-red	840
A14	TNL-080-green	335	B14	TNL-080-blue	330	C14	TNL-080-blue	330	D14	TNL-080-blue	335	br17	TNL-080-red	900
A14	TNL-080-green	355	B17	TNL-080-blue	345	C17	TNL-080-blue	340	D17	TNL-080-blue	345	br19	TNL-080-red	800
A18	TNL-080-green	300	B18	TNL-080-blue	295	C18	TNL-080-blue	290	D18	TNL-080-blue	290	br21	TNL-080-red	725
A21	TNL-080-green	325	B21	TNL-080-blue	305	C21	TNL-080-blue	295	D21	TNL-080-blue	295	br24	TNL-080-red	1460
A22	TNL-080-green	300	B22	TNL-080-blue	280	C22	TNL-080-blue	260	D22	TNL-080-blue	255			
A24	TNL-080-red	2195	B24	TNL-080-red	2175									
A25	TNL-080-red	2085	B25	TNL-080-red	2095	C25	TNL-080-red	2135						
2A1	TNL-140-green	2235	2B1	TNL-140-blue	2220	2C1	TNL-140-blue	2040	2D1	TNL-080-blue	1750	2BR1	TNL-080-red	1320
2A2	TNL-140-green	2180	2B2	TNL-140-blue	2175	2C2	TNL-140-blue	1995	2D2	TNL-080-blue	1705	2BR2	TNL-080-red	990
2A3	TNL-140-green	2140	2B3	TNL-140-blue	2115	2C3	TNL-140-blue	1930	2D3	TNL-080-blue	1660	2BR3	TNL-080-red	1025
2A4	TNL-140-green	2110	2B4	TNL-140-blue	2100	2C4	TNL-140-blue	1920	2D4	TNL-080-blue	1635	2BR4	TNL-080-red	1070
2A5	TNL-140-green	1825	2B5	TNL-140-blue	1735	2C5	TNL-080-blue	1790	2D5	TNL-080-blue	1860	2BR5	TNL-080-red	910
2A6	TNL-140-green	1625	2B6	TNL-140-blue	1565	2C6	TNL-080-blue	1615	2D6	TNL-080-blue	1670			
3A1	TNL-280-green	4345	3B1	TNL-280-blue	4275	3C1	TNL-280-blue	4475	3D1	TNL-220-blue	4880	3br1	TNL-080-red	2915
3A2	TNL-220-green	4335	3B2	TNL-220-blue	4290	3C2	TNL-220-blue	4490	3D2	TNL-220-blue	4860	3br2	TNL-080-red	2760
3A3	TNL-220-green	4425	3B3	TNL-220-blue	4490	3C3	TNL-140-blue	4465				3br3	TNL-080-red	2880
						STAB	TNL-080-red	3865				4br1	TNL-280-red	2475

Point a: 2275

DONNEES SUSPENTES

LINK 29

REF.	CODE	m/m	REF.	CODE	m/m	REF.	CODE	m/m	REF.	CODE	m/m	REF.	CODE	m/m
A			B			C			D			BRAKE		
A1	TNL-080-green	380	B1	TNL-080-blue	375	C1	TNL-080-blue	380	D1	TNL-080-blue	385	br3	TNL-080-red	1115
A2	TNL-080-green	335	B2	TNL-080-blue	330	C2	TNL-080-blue	330	D2	TNL-080-blue	325	br5	TNL-080-red	895
A5	TNL-080-green	345	B5	TNL-080-blue	345	C5	TNL-080-blue	340	D5	TNL-080-blue	340	br7	TNL-080-red	1070
A6	TNL-080-green	370	B6	TNL-080-blue	365	C6	TNL-080-blue	370	D6	TNL-080-blue	375	br9	TNL-080-red	1025
A9	TNL-080-green	370	B9	TNL-080-blue	365	C9	TNL-080-blue	370	D9	TNL-080-blue	375	br11	TNL-080-red	1020
A10	TNL-080-green	330	B10	TNL-080-blue	330	C10	TNL-080-blue	325	D10	TNL-080-blue	320	br13	TNL-080-red	930
A13	TNL-080-green	325	B13	TNL-080-blue	320	C13	TNL-080-blue	315	D13	TNL-080-blue	315	br15	TNL-080-red	875
A14	TNL-080-green	350	B14	TNL-080-blue	345	C14	TNL-080-blue	345	D14	TNL-080-blue	350	br17	TNL-080-red	940
A14	TNL-080-green	375	B17	TNL-080-blue	360	C17	TNL-080-blue	355	D17	TNL-080-blue	360	br19	TNL-080-red	840
A18	TNL-080-green	315	B18	TNL-080-blue	305	C18	TNL-080-blue	305	D18	TNL-080-blue	305	br21	TNL-080-red	760
A21	TNL-080-green	340	B21	TNL-080-blue	320	C21	TNL-080-blue	305	D21	TNL-080-blue	305	br24	TNL-080-red	1525
A22	TNL-080-green	315	B22	TNL-080-blue	290	C22	TNL-080-blue	270	D22	TNL-080-blue	265			
A24	TNL-080-red	2310	B24	TNL-080-red	2275									
A25	TNL-080-red	2180	B25	TNL-080-red	2190	C25	TNL-080-red	2235						
2A1	TNL-140-green	2335	2B1	TNL-140-blue	2320	2C1	TNL-140-blue	2130	2D1	TNL-080-blue	1830	2BR1	TNL-080-red	1380
2A2	TNL-140-green	2280	2B2	TNL-140-blue	2275	2C2	TNL-140-blue	2085	2D2	TNL-080-blue	1780	2BR2	TNL-080-red	1035
2A3	TNL-140-green	2235	2B3	TNL-140-blue	2210	2C3	TNL-140-blue	2020	2D3	TNL-080-blue	1735	2BR3	TNL-080-red	1075
2A4	TNL-140-green	2205	2B4	TNL-140-blue	2195	2C4	TNL-140-blue	2005	2D4	TNL-080-blue	1710	2BR4	TNL-080-red	1120
2A5	TNL-140-green	1905	2B5	TNL-140-blue	1815	2C5	TNL-080-blue	1870	2D5	TNL-080-blue	1940	2BR5	TNL-080-red	955
2A6	TNL-140-green	1695	2B6	TNL-140-blue	1635	2C6	TNL-080-blue	1690	2D6	TNL-080-blue	1745			
3A1	TNL-280-green	4540	3B1	TNL-280-blue	4470	3C1	TNL-280-blue	4680	3D1	TNL-220-blue	5100	3br1	TNL-080-red	3045
3A2	TNL-220-green	4530	3B2	TNL-220-blue	4480	3C2	TNL-220-blue	4690	3D2	TNL-220-blue	5080	3br2	TNL-080-red	2885
3A3	TNL-220-green	4635	3B3	TNL-220-blue	4695	3C3	TNL-140-blue	4665				3br3	TNL-080-red	3005
						STAB	TNL-080-red	4035				4br1	TNL-280-red	2575

Point a: 2375

NIVIUK LINK 23

LONGUEURS TOTALES m/m					
	A	B	C	D	br
1	6380	6300	6320	6430	7000
2	6340	6265	6275	6380	6805
3	6305	6230	6245	6350	6660
4	6325	6250	6270	6385	6620
5	6275	6210	6220	6325	6505
6	6240	6175	6180	6280	6425
7	6215	6155	6165	6250	6420
8	6230	6180	6190	6280	6475
9	6080	6045	6070	6135	6340
10	6030	5995	6020	6085	6270
11	5865	5845	5860	5910	6105
12	5840	5825	5830	5875	
13	5595	5565			
14	5480	5485	5520		
15					

LONGUEURS DES ELEVATEURS m/m					
	A	B	C	D	
	480	480	480	480	NEUTRE
	480	480	525	570	AFFICHEURS OUVERTS
	380	410	440	480	ACCELEREE

NIVIUK LINK 25

LONGUEURS TOTALES m/m					
	A	B	C	D	br
1	6655	6570	6590	6710	7270
2	6610	6530	6545	6655	7070
3	6575	6495	6515	6625	6915
4	6595	6520	6540	6655	6875
5	6545	6470	6495	6595	6750
6	6510	6435	6455	6545	6670
7	6475	6415	6430	6515	6660
8	6495	6435	6455	6550	6720
9	6332	6295	6325	6390	6575
10	6277	6250	6275	6340	6505
11	6102	6090	6100	6150	6335
12	6077	6065	6070	6115	
13	5800	5770			
14	5680	5690	5725		
15					

LONGUEURS DES ELEVATEURS m/m					
	A	B	C	D	
	480	480	480	480	NEUTRE
	480	480	525	570	AFFICHEURS OUVERTS
	380	410	440	480	ACCELEREE

NIVIUK LINK 27

LONGUEURS TOTALES m/m					
	A	B	C	D	br
1	6915	6830	6850	6975	7535
2	6875	6790	6805	6920	7325
3	6830	6755	6770	6885	7165
4	6855	6775	6800	6920	7120
5	6805	6730	6750	6855	6995
6	6765	6695	6705	6800	6910
7	6730	6670	6685	6770	6905
8	6755	6695	6715	6805	6965
9	6580	6545	6570	6645	6825
10	6525	6495	6520	6590	6750
11	6345	6330	6345	6400	6575
12	6320	6305	6310	6360	
13	6030	6010			
14	5920	5930	5970		
15					

LONGUEURS DES ELEVATEURS m/m					
	A	B	C	D	
	480	480	480	480	NEUTRE
	480	480	525	570	AFFICHEURS OUVERTS
	380	410	440	480	ACCELEREE

NIVIUK LINK 29

LONGUEURS TOTALES m/m					
	A	B	C	D	br
1	7245	7151	7182	7309	7900
2	7199	7106	7132	7249	7680
3	7153	7077	7097	7213	7510
4	7180	7099	7130	7249	7465
5	7127	7047	7072	7179	7340
6	7087	7014	7027	7123	7250
7	7053	6989	7000	7092	7240
8	7077	7014	7029	7128	7305
9	6899	6858	6877	6951	7160
10	6840	6801	6826	6897	7080
11	6654	6639	6646	6701	6890
12	6627	6609	6609	6656	
13	6334	6297			
14	6204	6213	6259		
15					

LONGUEURS DES ELEVATEURS m/m					
	A	B	C	D	
	480	480	480	480	NEUTRE
	480	480	525	570	AFFICHEURS OUVERTS
	380	410	440	480	ACCELEREE

DONNEES TECHNIQUES SUSPENTAGE

CODE MATERIEL		TNL	TNL	TNL	TNL	TNL
CODE CHARGE		080	140	220	280	400
CODE COULEUR		GREEN	GREEN	GREEN	GREEN	
		BLUE	BLUE	BLUE	BLUE	
		RED				RED
DIAMETRE EN M/M	Ø	1,1	1,4	1,6	1,8	2,3
MATERIEL AME		TECHNORA	TECHNORA	TECHNORA	TECHNORA	TECHNORA
MATERIEL GAINÉ		POLYESTER	POLYESTER	POLYESTER	POLYESTER	POLYESTER
POIDS METRIQUE G/M	TOTAL	1,1	1,96	2,35	2,7	4
CHARGE DE RUPTURE	MINIMUM	80	140	220	280	460
	MAXIMUM	92	160	250	320	470
RESISTANCE APRES						
5.000 CYCLES	TEST EN	36,7	76,1	114,2	134,7	160,1
DE FLEXION						
ALLONGEMENT A	5 DAN EN %	0,3	0,2	0,2	0,2	0,05
	10 DAN EN %	0,5	0,3	0,3	0,3	0,1
	15 DAN EN %	0,7	0,5	0,5	0,4	0,2
	20 DAN EN %	1	0,6	0,6	0,4	0,2
	25 DAN EN %	1,3	0,8	0,7	0,5	0,3
	30 DAN EN %	2,3	1,5	1,2	0,9	0,6
	75 DAN EN %	2,8	2,3	1,8	1,3	0,8
	100 DAN EN %		2,7	2,2	1,7	1,1
	125 DAN EN %		3,2	2,7	2	1,4
	150 DAN EN %			3	2,3	1,7
	175 DAN EN %			3,3	2,7	2
	200 DAN EN %			3,8	2,8	2,2
ALLONGEMENT A LA CHARGE DE RUPTURE %	3	3,4	4	4,1	4,6	

DONNEES TECHNIQUES MAILLON & POULIE

DESCRIPTION

MAILLON	DELTA
REF.	MRI4
MATERIEL	STAINLESS STEEL
DIAMETRE	4,3 M/M
POIDS	12 G/PIECE

SPECIFICATIONS TECHNIQUES

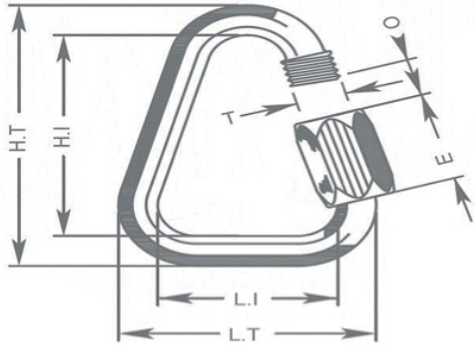

DIMENSIONS	M/M
L.T.	28
L.I.	20
H.T.	38
H.I.	30
O	4
E	11
T	4
CHARGE	KG
UTILE	150
RUPTURE	750

MATERIEL

AISI 304 STAINLES STEEL STANDARD

CLOSING APLIED BY MANUAL & ENTIRE SCREWING OF THE NUT

POUR GARANTIR LA PLUS HAUTE SECURITE

CONTROLE SYSTEMATIQUE DES MAILLONS RAPIDES AVANT CHAQUE VOL

DONNEES TECHNIQUES FIL

CARACTERISTIQUES DU FIL DE COUTURE

NOM	SERAFIL
N° DE REFERENCE	60
MATERIEL	POLYESTER
FINITION	SILK
DENSITE LINEAIRE	NM 61 / 3 (DTEX 163 * 3)
CHARGE DE RUPTURE	3,000 CN
ALLONGEMENT	17,00%

PROPRIETE SERAFIL

SOLIDITE A LA LUMIERE ARTIFICIELLE	ISO 105 B02	> 5 - 6
SOLIDITE A LA SUEUR	ISO 105 E04	> 4
SOLIDITE AU LAVAGE	ISO 105 C04	> 3
SOLIDITE AU FROTTEMENT A SEC	ISO 105 X12	> 4
SOLIDITE AU LAVAGE EN SECHERESSE	ISO 105 D01	> 3 - 4

DEPERLANT

WR

CARACTERISTIQUES DES ELEVATEURS

NOM	COATS BONDED C.F.P.
N° DE REFERENCE	V138
MATERIEL	POLYESTER
FINITION	SILK
CHARGE DE RUPTURE	9,5 KG
ALLONGEMENT	19%

DONNEES TECHNIQUES SANGLES

ELEVATEURS

REFERENCE	G-R 22
MATERIEL	POLYESTER
LARGEUR	22 M/M
EPAISSEUR	1,52 M/M
CHARGE DE RUPTURE	1,100 DAN
ALLONGEMENT	MAX. 15%
POIDS	25 G* L.M.
COULEUR	BLACK

INDICATEUR DE COULEUR

REFERENCE	IC-G 1-2
MATERIEL	POLYESTER
LARGEUR	70 M/M
EPAISSEUR	0,80 M/M
CHARGE DE RUPTURE	130 DN
ALLONGEMENT	35 %
POIDS	32 G * L.M.
COULEUR	GREEN

POINT D'ATTACHE

REFERENCE	LKI - 10
MATERIEL	NYLON
LARGEUR	10 M/M
CHARGE DE RUPTURE	84 KG
ALLONGEMENT	30 %
POIDS	5,5 G/M
COULEUR	WHITE

