

# DONNEES TECHNIQUES



ZION

## DONNEES TECHNIQUES

<b>ZION</b>		<b>15</b>	<b>17</b>	<b>19</b>	
ALVEOLES	NOMBRE	37	37	37	
	FERMEES	4	4	4	
	CAISSONS	31	31	31	
A PLAT	SURFACE	M2	15	17	19
	ENVERGURE	M	8,57	9,13	9,65
	ALLONGEMENT		4,9	4,9	4,9
PROJETEE	SURFACE	M2	12,85	14,53	16,21
	ENVERGURE	M	6,81	8,54	9,13
	ALLONGEMENT		3,69	3,69	3,69
APLATISSEMENT	%	15	15	15	
CORDE	MAXIMUM	M	2,13	2,27	2,39
	MINIMUM	M	0,5	0,53	0,56
	MOYENNE	M	1,75	1,86	1,96
SUSPENTES	TOTAL	M	271	289	306
	HAUTEUR	M	5,06	5,39	5,69
	NOMBRE		244	244	244
	REPARTITION		3/4/3/2	3/4/3/2	3/4/3/2
ELEVATEURS	NOMBRE	4	A/B/C/D	A/B/C/D	A/B/C/D
	AFFICHEURS	CM	14	14	14
	ACCELERATEUR		NO	NO	NO
POIDS TOTAL EN VOL (PILOTE+AILE+EQUIPEMENT)	KG	91	103	115	
POIDS DE L'AILE	KG	3,6	3,9	4,3	
HOMOLOGATION	EN	926-1	926-1	926-1	

## MATERIAUX

<b>VOILERIE</b>	<b>MATERIAUX</b>	<b>FABRICANT</b>
EXTRADOS	SKYTEX 40 9017 E77	PORCHER IND (FRANCE)
INTRADOS	SKYTEX 40 9017 E38A	PORCHER IND (FRANCE)
PROFIL	SKYTEX 40 9017 E29	PORCHER IND (FRANCE)
DIAGONALES	SKYTEX 40 9017 E29	PORCHER IND (FRANCE)
POINT D' ATTACHE	LKI - 10	KOLON IND. (KOREA)
RENFORT DU POINT D' ATTACHE	W-420	D-P (GERMANY)
RENFORT DU BORD DE FUITE	MYLAR	D-P (GERMANY)
RENFORT CLOISONS	W-420	D-P (GERMANY)
FIL	SERAFIL 60	AMAN (GERMANY)

<b>SUSPENTAGE</b>	<b>MATERIAUX</b>	<b>FABRICANT</b>
CASCADES SUPERIEURES	TNL - 080	TEIJIM LIMITED (JAPAN)
CASCADES INTERMEDIAIRES	TNL - 080	TEIJIM LIMITED (JAPAN)
CASCADES INTERMEDIAIRES	TNL - 140	TEIJIM LIMITED (JAPAN)
CASCADES PRINCIPALES	TNL - 140	TEIJIM LIMITED (JAPAN)
CASCADES PRINCIPALES	TNL - 220	TEIJIM LIMITED (JAPAN)
CASCADES PRINCIPALES	TNL - 280	TEIJIM LIMITED (JAPAN)
CASCADES PRINCIPALES FREIN	TNL - 400	TEIJIM LIMITED (JAPAN)
FIL	SERAFIL 60	AMAN (GERMANY)

<b>ELEVATEURS</b>	<b>MATERIAUX</b>	<b>FABRICANT</b>
SANGLES	G-R 22	TECNI SANGLES (FRANCE)
INDICATEUR DE COULEUR	PAD	TECNI SANGLES (FRANCE)
FIL	V138	COATS (ENGLAND)
MAILLONS	MRI4	ANSUNG PRECISION (KOREA)
POULIE	PY-1304-2	ANSUNG PRECISION (KOREA)



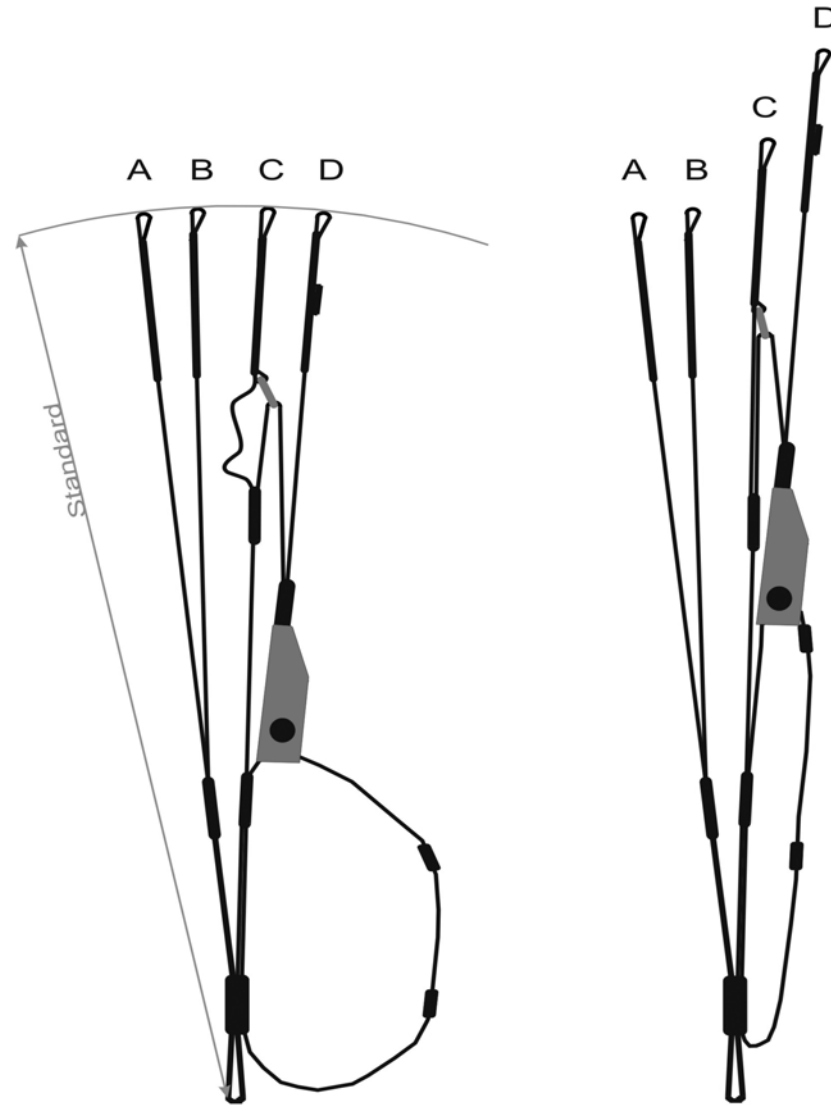

Riser ZION	<b>A</b>	<b>B</b>	<b>C</b>	<b>D</b>
Standard	470	470	470	470
Trimer	470	470	540	610
Travel	0	0	70	140

**DONNEES TECHNIQUES DES COULEURS**

SKY	1	DEEP BLUE	COULEUR EXTRADOS	REF: 354
	2	WHITE	MOUSTACHE	REF: 001
	3	DARK RED	LISERET	REF: 615
	4	DEEP BLUE	COULEUR INTRADOS	REF: 354



LIMA	1	LIGHT GREEN	COULEUR EXTRADOS	REF: 521
	2	BLACK	MOUSTACHE	REF: 102
	3	GOLD	LISERET	REF: 939
	4	LIGHT GREEN	COULEUR INTRADOS	REF: 521

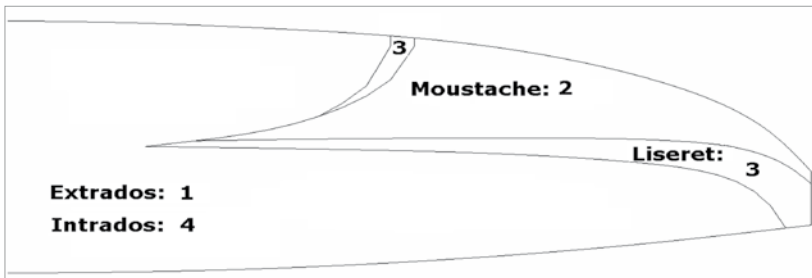

**DONNEES TECHNIQUES CHARGE ALAIRE**

ZION	15			17			19		
	P.T.V.	KG/M2	NIVEL	P.T.V.	KG/M2	NIVEL	P.T.V.	KG/M2	NIVEL
	69	= 4,6	SPORT	61	= 3,6	ROOKIE	55	= 2,9	ROOKIE
		4,7	SPORT		3,7	ROOKIE		3	ROOKIE
	73	= 4,9	SPORT		3,8	ROOKIE		3,1	ROOKIE
	75	= 5	EXPERT		3,9	ROOKIE		3,2	ROOKIE
		5,1	EXPERT	69	= 4,1	ROOKIE		3,3	ROOKIE
		5,3	EXPERT	71	= 4,2	SPORT		3,4	ROOKIE
		5,4	EXPERT		4,3	SPORT		3,5	ROOKIE
		5,5	EXPERT		4,4	SPORT		3,6	ROOKIE
		5,7	EXPERT		4,5	SPORT		3,7	ROOKIE
		5,8	EXPERT		4,6	SPORT		3,8	ROOKIE
		5,9	EXPERT		4,8	SPORT		3,9	ROOKIE
	91	= 6,1	EXPERT		4,9	SPORT		4,1	ROOKIE
					5	SPORT		4,2	ROOKIE
					5,1	SPORT		4,3	ROOKIE
				90	= 5,2	SPORT		4,4	ROOKIE
				91	= 5,4	EXPERT	85	= 4,5	ROOKIE
					5,5	EXPERT	87	= 4,6	SPORT
					5,6	EXPERT		4,7	SPORT
					5,7	EXPERT		4,8	SPORT
					5,8	EXPERT		4,9	SPORT
					5,9	EXPERT		5	SPORT
				103	= 6,1	EXPERT		5,1	SPORT
								5,2	SPORT
								5,3	SPORT
								5,4	SPORT
								5,5	SPORT
								5,6	SPORT
								5,7	SPORT
							111	= 5,8	SPORT
								5,9	EXPERT
							115	= 6,1	EXPERT

**DONNEES SUSPENTES**

**ZION 15**

REF.	CODE	CM.	REF.	CODE	CM.	REF.	CODE	CM.	REF.	CODE	CM.	REF.	CODE	CM.
<b>A</b>			<b>B</b>			<b>C</b>			<b>D</b>			<b>BRAKE</b>		
A1	TNL-080-YLW	74,5	B1	TNL-080-BLU	74	C1	TNL-080-BLU	60,5	D1	TNL-080-BLU	45	BR2	TNL-080-RED	94
A2	TNL-080-YLW	69,5	B2	TNL-080-BLU	69,5	C2	TNL-080-BLU	54,5	D2	TNL-080-BLU	38,5	BR4	TNL-080-RED	71
A3	TNL-080-YLW	73	B3	TNL-080-BLU	72,5	C3	TNL-080-BLU	58	D3	TNL-080-BLU	41	BR6	TNL-080-RED	38
A4	TNL-080-YLW	73,5	B4	TNL-080-BLU	73	C4	TNL-080-BLU	59,5	D4	TNL-080-BLU	43,5	BR7	TNL-080-RED	35
A6	TNL-080-YLW	73,5	B6	TNL-080-BLU	73	C6	TNL-080-BLU	59,5	D6	TNL-080-BLU	44	BR8	TNL-080-RED	73,5
A7	TNL-080-YLW	69	B7	TNL-080-BLU	68,5	C7	TNL-080-BLU	53,5	D7	TNL-080-BLU	36,5	BR9	TNL-080-RED	64
A8	TNL-080-YLW	143	B8	TNL-080-BLU	141	C8	TNL-080-BLU	111,5	D8	TNL-080-BLU	78,5	BR10	TNL-080-RED	62,5
A9	TNL-080-YLW	141	B9	TNL-080-BLU	139,5	C9	TNL-080-BLU	110,5	D9	TNL-080-BLU	78	BR11	TNL-080-RED	62
A10	TNL-080-YLW	142,5	B10	TNL-080-BLU	141,5	C10	TNL-080-BLU	114	D10	TNL-080-BLU	84	BR12	TNL-080-RED	61,5
A12	TNL-080-YLW	134	B12	TNL-080-BLU	129,5	C12	TNL-080-BLU	111,5	D12	TNL-080-BLU	76	BR13	TNL-080-RED	67
A13	TNL-080-YLW	128,5	B13	TNL-080-BLU	125	C13	TNL-080-BLU	106,5	D13	TNL-080-BLU	69,5	BR14	TNL-080-RED	49,5
A14	TNL-080-YLW	125	B14	TNL-080-BLU	122	C14	TNL-080-BLU	103,5	D14	TNL-080-BLU	68	BR15	TNL-080-RED	43
A15	TNL-080-YLW	125,5	B15	TNL-080-BLU	116	C15	TNL-080-BLU	96,5	D15	TNL-080-BLU	64,5	BR16	TNL-080-RED	42,5
A16	TNL-080-YLW	121	B16	TNL-080-BLU	112	C16	TNL-080-BLU	92,5	D16	TNL-080-BLU	60			
A17	TNL-080-YLW	117,5	B17	TNL-080-BLU	109	C17	TNL-080-BLU	90	D17	TNL-080-BLU	58,5			
A19	TNL-080-RED	109,5	B19	TNL-080-RED	107	C19	TNL-080-RED	108,5						
2 A1	TNL-140-YLW	93	2 B1	TNL-140-BLU	92,5	2 C1	TNL-140-BLU	73	2 D1	TNL-140-BLU	72	2 BR1	TNL-080-RED	118
2 A2	TNL-140-YLW	87,5	2 B2	TNL-140-BLU	87	2 C2	TNL-140-BLU	67,5	2 D2	TNL-140-BLU	67	2 BR2	TNL-080-RED	132
2 A3	TNL-140-YLW	129	2 B3	TNL-140-BLU	127,5	2 C3	TNL-140-BLU	100,5	2 D3	TNL-140-BLU	76	2 BR3	TNL-080-RED	79
2 A4	TNL-140-YLW	52	2 B4	TNL-140-BLU	52,5	2 C4	TNL-140-BLU	39,5	2 D4	TNL-140-BLU	30	2 BR4	TNL-080-RED	77,5
2 A5	TNL-140-YLW	70	2 B5	TNL-140-BLU	65	2 C5	TNL-140-BLU	53	2 D5	TNL-140-BLU	97	2 BR5	TNL-080-RED	52,5
2 A6	TNL-140-YLW	65	2 B6	TNL-140-BLU	66,5	2 C6	TNL-140-BLU	56	2 D6	TNL-140-BLU	94,5	2 BR6	TNL-080-RED	91,5
3 A1	TNL-280-YLW	335,5	3 B1	TNL-280-BLU	330	3 C1	TNL-280-BLU	366	3 D1	TNL-220-BLU	392,5	3 BR1	TNL-140-RED	207,5
3 A2	TNL-220-YLW	289,5	3 B2	TNL-220-BLU	285,5	3 C2	TNL-220-BLU	330	3 D2	TNL-220-BLU	380,5	3 BR2	TNL-140-RED	216
3 A3	TNL-220-YLW	273	3 B3	TNL-220-BLU	279	3 C3	TNL-220-BLU	312				3 BR3	TNL-140-RED	248,5
			STAB	TNL-140-PNK	323,5							4 BR1	TNL-400-RED	171
													POINT AT:	151

**DONNEES SUSPENTES**

**ZION 17**

REF.	CODE	CM.	REF.	CODE	CM.	REF.	CODE	CM.	REF.	CODE	CM.	REF.	CODE	CM.
<b>A</b>			<b>B</b>			<b>C</b>			<b>D</b>			<b>BRAKE</b>		
A1	TNL-080-YLW	79	B1	TNL-080-BLU	79	C1	TNL-080-BLU	64	D1	TNL-080-BLU	47,5	BR2	TNL-080-RED	101
A2	TNL-080-YLW	74	B2	TNL-080-BLU	74	C2	TNL-080-BLU	58	D2	TNL-080-BLU	41	BR4	TNL-080-RED	75,5
A3	TNL-080-YLW	77,5	B3	TNL-080-BLU	77	C3	TNL-080-BLU	61,5	D3	TNL-080-BLU	44	BR6	TNL-080-RED	40,5
A4	TNL-080-YLW	78	B4	TNL-080-BLU	78	C4	TNL-080-BLU	63,5	D4	TNL-080-BLU	46,5	BR7	TNL-080-RED	37,5
A6	TNL-080-YLW	78,5	B6	TNL-080-BLU	78	C6	TNL-080-BLU	63	D6	TNL-080-BLU	47	BR8	TNL-080-RED	78,5
A7	TNL-080-YLW	73,5	B7	TNL-080-BLU	73	C7	TNL-080-BLU	57	D7	TNL-080-BLU	39	BR9	TNL-080-RED	68
A8	TNL-080-YLW	152	B8	TNL-080-BLU	150	C8	TNL-080-BLU	118,5	D8	TNL-080-BLU	83,5	BR10	TNL-080-RED	66,5
A9	TNL-080-YLW	150,5	B9	TNL-080-BLU	148,5	C9	TNL-080-BLU	117,5	D9	TNL-080-BLU	83	BR11	TNL-080-RED	66
A10	TNL-080-YLW	152	B10	TNL-080-BLU	150,5	C10	TNL-080-BLU	121,5	D10	TNL-080-BLU	89,5	BR12	TNL-080-RED	65,5
A12	TNL-080-YLW	142,5	B12	TNL-080-BLU	138	C12	TNL-080-BLU	119	D12	TNL-080-BLU	81	BR13	TNL-080-RED	71,5
A13	TNL-080-YLW	137	B13	TNL-080-BLU	133	C13	TNL-080-BLU	113,5	D13	TNL-080-BLU	74	BR14	TNL-080-RED	53
A14	TNL-080-YLW	133,5	B14	TNL-080-BLU	130	C14	TNL-080-BLU	110	D14	TNL-080-BLU	72,5	BR15	TNL-080-RED	46
A15	TNL-080-YLW	133,5	B15	TNL-080-BLU	123,5	C15	TNL-080-BLU	102,5	D15	TNL-080-BLU	68,5	BR16	TNL-080-RED	45,5
A16	TNL-080-YLW	128,5	B16	TNL-080-BLU	119,5	C16	TNL-080-BLU	98,5	D16	TNL-080-BLU	64			
A17	TNL-080-YLW	125,5	B17	TNL-080-BLU	116,5	C17	TNL-080-BLU	96	D17	TNL-080-BLU	62,5			
A19	TNL-080-RED	113	B19	TNL-080-RED	113,5	C19	TNL-080-RED	117,5						
2 A1	TNL-140-YLW	99	2 B1	TNL-140-BLU	98,5	2 C1	TNL-140-BLU	78	2 D1	TNL-140-BLU	76,5	2 BR1	TNL-080-RED	126,5
2 A2	TNL-140-YLW	93	2 B2	TNL-140-BLU	93	2 C2	TNL-140-BLU	72	2 D2	TNL-140-BLU	71	2 BR2	TNL-080-RED	140,5
2 A3	TNL-140-YLW	137,5	2 B3	TNL-140-BLU	136	2 C3	TNL-140-BLU	106,5	2 D3	TNL-140-BLU	81	2 BR3	TNL-080-RED	84
2 A4	TNL-140-YLW	55,5	2 B4	TNL-140-BLU	56	2 C4	TNL-140-BLU	42	2 D4	TNL-140-BLU	31,5	2 BR4	TNL-080-RED	82,5
2 A5	TNL-140-YLW	74,5	2 B5	TNL-140-BLU	69	2 C5	TNL-140-BLU	56,5	2 D5	TNL-140-BLU	103	2 BR5	TNL-080-RED	56
2 A6	TNL-140-YLW	69,5	2 B6	TNL-140-BLU	71	2 C6	TNL-140-BLU	59,5	2 D6	TNL-140-BLU	101	2 BR6	TNL-080-RED	97,5
3 A1	TNL-280-YLW	356,5	3 B1	TNL-280-BLU	351	3 C1	TNL-280-BLU	390	3 D1	TNL-220-BLU	418,5	3 BR1	TNL-140-RED	264,5
3 A2	TNL-220-YLW	307	3 B2	TNL-220-BLU	303,5	3 C2	TNL-220-BLU	351,5	3 D2	TNL-220-BLU	406	3 BR2	TNL-140-RED	230
3 A3	TNL-220-YLW	290,5	3 B3	TNL-220-BLU	297,5	3 C3	TNL-220-BLU	332,5				3 BR3	TNL-140-RED	221
			STAB	TNL-140-PNK	347							4 BR1	TNL-400-RED	181
													POINT AT:	161

**DONNEES SUSPENTES**

**ZION 19**

REF.	CODE	CM.	REF.	CODE	CM.	REF.	CODE	CM.	REF.	CODE	CM.	REF.	CODE	CM.
<b>A</b>			<b>B</b>			<b>C</b>			<b>D</b>			<b>BRAKE</b>		
A1	TNL-080-YLW	83,5	B1	TNL-080-BLU	83	C1	TNL-080-BLU	68	D1	TNL-080-BLU	50,5	BR2	TNL-080-RED	106,5
A2	TNL-080-YLW	78	B2	TNL-080-BLU	78	C2	TNL-080-BLU	61,5	D2	TNL-080-BLU	43	BR4	TNL-080-RED	79,5
A3	TNL-080-YLW	82	B3	TNL-080-BLU	81,5	C3	TNL-080-BLU	65	D3	TNL-080-BLU	46,5	BR6	TNL-080-RED	43
A4	TNL-080-YLW	82,5	B4	TNL-080-BLU	82,5	C4	TNL-080-BLU	67	D4	TNL-080-BLU	49	BR7	TNL-080-RED	39,5
A6	TNL-080-YLW	83	B6	TNL-080-BLU	82,5	C6	TNL-080-BLU	67	D6	TNL-080-BLU	49,5	BR8	TNL-080-RED	83
A7	TNL-080-YLW	77,5	B7	TNL-080-BLU	77,5	C7	TNL-080-BLU	60,5	D7	TNL-080-BLU	41	BR9	TNL-080-RED	72
A8	TNL-080-YLW	160,5	B8	TNL-080-BLU	158,5	C8	TNL-080-BLU	125,5	D8	TNL-080-BLU	88	BR10	TNL-080-RED	70
A9	TNL-080-YLW	159	B9	TNL-080-BLU	157	C9	TNL-080-BLU	124,5	D9	TNL-080-BLU	88	BR11	TNL-080-RED	69,5
A10	TNL-080-YLW	160,5	B10	TNL-080-BLU	159,5	C10	TNL-080-BLU	128,5	D10	TNL-080-BLU	94,5	BR12	TNL-080-RED	69,5
A12	TNL-080-YLW	150,5	B12	TNL-080-BLU	146	C12	TNL-080-BLU	125,5	D12	TNL-080-BLU	85,5	BR13	TNL-080-RED	75,5
A13	TNL-080-YLW	145	B13	TNL-080-BLU	140,5	C13	TNL-080-BLU	120	D13	TNL-080-BLU	78,5	BR14	TNL-080-RED	56
A14	TNL-080-YLW	141	B14	TNL-080-BLU	137,5	C14	TNL-080-BLU	116,5	D14	TNL-080-BLU	76,5	BR15	TNL-080-RED	48,5
A15	TNL-080-YLW	141	B15	TNL-080-BLU	130,5	C15	TNL-080-BLU	108,5	D15	TNL-080-BLU	72,5	BR16	TNL-080-RED	48
A16	TNL-080-YLW	136	B16	TNL-080-BLU	126	C16	TNL-080-BLU	104,5	D16	TNL-080-BLU	67,5			
A17	TNL-080-YLW	132,5	B17	TNL-080-BLU	123	C17	TNL-080-BLU	101,5	D17	TNL-080-BLU	66,5			
A19	TNL-080-RED	119,5	B19	TNL-080-RED	119,5	C19	TNL-080-RED	124						
2 A1	TNL-140-YLW	104,5	2 B1	TNL-140-BLU	104	2 C1	TNL-140-BLU	82,5	2 D1	TNL-140-BLU	81	2 BR1	TNL-080-RED	133
2 A2	TNL-140-YLW	98,5	2 B2	TNL-140-BLU	98	2 C2	TNL-140-BLU	76	2 D2	TNL-140-BLU	75	2 BR2	TNL-080-RED	148,5
2 A3	TNL-140-YLW	145	2 B3	TNL-140-BLU	143,5	2 C3	TNL-140-BLU	113	2 D3	TNL-140-BLU	85,5	2 BR3	TNL-080-RED	89
2 A4	TNL-140-YLW	58,5	2 B4	TNL-140-BLU	59	2 C4	TNL-140-BLU	44,5	2 D4	TNL-140-BLU	33,5	2 BR4	TNL-080-RED	87,5
2 A5	TNL-140-YLW	78,5	2 B5	TNL-140-BLU	73	2 C5	TNL-140-BLU	59,5	2 D5	TNL-140-BLU	109	2 BR5	TNL-080-RED	59
2 A6	TNL-140-YLW	73,5	2 B6	TNL-140-BLU	75	2 C6	TNL-140-BLU	63	2 D6	TNL-140-BLU	106,5	2 BR6	TNL-080-RED	103
3 A1	TNL-280-YLW	377	3 B1	TNL-280-BLU	371	3 C1	TNL-280-BLU	412,5	3 D1	TNL-220-BLU	443	3 BR1	TNL-140-RED	233,5
3 A2	TNL-220-YLW	325	3 B2	TNL-220-BLU	321	3 C2	TNL-220-BLU	371,5	3 D2	TNL-220-BLU	429,5	3 BR2	TNL-140-RED	243
3 A3	TNL-220-YLW	307	3 B3	TNL-220-BLU	314,5	3 C3	TNL-220-BLU	352				3 BR3	TNL-140-RED	279,5
			STAB	TNL-140-PNK	367							4 BR1	TNL-400-RED	189,5
													POINT AT:	169,5

**NIVIUK ZION 15**

LONGUEURS TOTALES CM.					
	<b>A</b>	<b>B</b>	<b>C</b>	<b>D</b>	<b>BR</b>
1	500	493,5	496,5	506,5	567,5
2	495	489	490,5	500	544,5
3	493	486,5	488,5	497,5	525,5
4	493,5	487	490	500	522,5
5	489	483	487	497,5	516,5
6	484,5	478,5	481	490	507
7	481,5	476	478	486	505,5
8	479,5	474,5	477	485,5	503,5
9	481	476,5	480,5	491,5	503
10	474	470,5	473	481,5	508,5
11	468,5	466	468	475	498,5
12	465	463	465	473,5	492
13	460,5	458,5	461	467,5	491,5
14	456	454,5	457	463	488
15	452,5	451,5	454,5	461,5	
STB	431,5	429	430,5		

LONGUEURS DES ELEVATEURS CM.					
	<b>A</b>	<b>B</b>	<b>C</b>	<b>D</b>	
	47	47	47	47	STANDARD
	47	47	54	61	TRIMS OUVERTS
	0	0	7	14	PARCOURS

**NIVIUK ZION 17**

LONGUEURS TOTALES CM.					
	<b>A</b>	<b>B</b>	<b>C</b>	<b>D</b>	<b>BR</b>
1	531,5	525,5	529	539,5	606,5
2	526,5	520,5	523	533	581
3	524	518	520,5	530,5	560
4	524,5	519	522,5	533	557
5	520	514,5	518	531	550,5
6	515	509,5	512	523	540
7	511,5	506,5	509	518	538,5
8	510	505	508	517,5	536,5
9	511,5	507	512	524	536
10	504,5	501,5	504,5	513,5	542
11	499	496,5	499	506,5	531,5
12	495,5	493,5	495,5	505	524,5
13	490,5	489	491	498,5	524
14	485,5	485	487	494	520
15	482,5	482	484,5	492,5	
STB	458,5	459	463		

LONGUEURS DES ELEVATEURS CM.					
	<b>A</b>	<b>B</b>	<b>C</b>	<b>D</b>	
	38	38	38	38	STANDARD
	38	41	44	50,5	TRIMS OUVERTS
	0	3	6	12,5	PARCOURS

LONGUEURS TOTALES CM.

	<b>A</b>	<b>B</b>	<b>C</b>	<b>D</b>	<b>BR</b>
1	562	555	560	571,5	639,7
2	556,5	550	553,5	564	612,7
3	554,5	547,5	550,5	561,5	591,7
4	555	548,5	552,5	564	588,2
5	550	544	548,5	561,5	581,7
6	544,5	539	542	553	570,7
7	541	535,5	538,5	548	568,7
8	539,5	534	537,5	548	566,7
9	541	536,5	541,5	554,5	566,7
10	533	530,5	533,5	543	572,7
11	527,5	525	528	536	561,2
12	523,5	522	524,5	534	553,7
13	518,5	517	520	527,5	553,2
14	513,5	512,5	516	522,5	549,2
15	510	509,5	513	521,5	
STB	485	485	489,5		

LONGUEURS DES ELEVATEURS CM.

	<b>A</b>	<b>B</b>	<b>C</b>	<b>D</b>	
	38	38	38	38	STANDARD
	38	41	44	505	TRIMS OUVERTS
	0	3	6	125	PARCOURS

**DONNEES TECHNIQUES SUSPENTAGE**

CODE MATERIEL	TEJIM NIVIUK LINES	TNL	TNL	TNL	TNL	TNL
CODE CHARGE	DAN	080	140	220	280	400
CODE COULEUR	YLW	YLW	YLW	YLW	YLW	
	BLU	BLU	BLU	BLU	BLU	
	RED	RED	RED			RED
DIAMETRE EN M/M	Ø	1,1	1,4	1,6	1,8	2,3
MATERIEL AME		TECHNORA	TECHNORA	TECHNORA	TECHNORA	TECHNORA
MATERIEL GAINE		POLYESTER	POLYESTER	POLYESTER	POLYESTER	POLYESTER
POIDS METRIQUE G/M	TOTAL	G. 1,1	1,2	2,35	2,7	4
	AME	G. 0,45	0,76	1,22	1,55	2,23
	GAINE	G. 0,65	1,2	1,13	1,15	1,77
CHARGE DE RUPTURE	MIN	DAN 80	140	220	280	460
	MAX	DAN 92	160	250	320	470
RESISTANCE APRES						
5.000 CYCLES	TEST EN	DAN 36,7	76,1	114,2	134,7	160,1
DE FLEXION						
ALLONGEMENT A	5 DAN EN %	0,3	0,2	0,2	0,2	0,05
	10 DAN EN %	0,5	0,3	0,3	0,3	0,1
	15 DAN EN %	0,7	0,5	0,5	0,4	0,2
	20 DAN EN %	1	0,6	0,6	0,4	0,2
	25 DAN EN %	1,3	0,8	0,7	0,5	0,3
	30 DAN EN %	2,3	1,5	1,2	0,9	0,6
	75 DAN EN %	2,8	2,3	1,8	1,3	0,8
	100 DAN EN %		2,7	2,2	1,7	1,1
	125 DAN EN %		3,2	2,7	2	1,4
	150 DAN EN %			3	2,3	1,7
	175 DAN EN %			3,3	2,7	2
	200 DAN EN %			3,8	2,8	2,2
ALLONGEMENT A LA CHARGE DE RUPTURE %		3	3,4	4	4,1	4,6

## DONNEES TECHNIQUES MAILLON

### DESCRIPTION

MAILLON	DELTA
REF.	MRI4
MATERIEL	ACIER INOX AISI 304
DIAMETRE	4,3 M/M
POIDS	12 G/PIECE

### SPECIFICATIONS TECHNIQUES

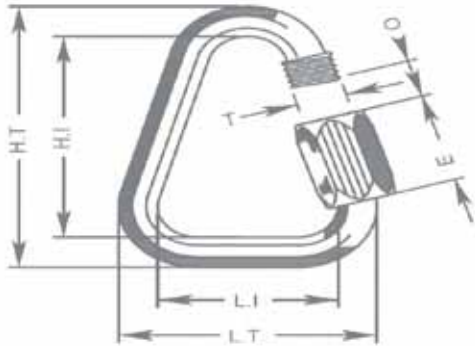

DIMENSIONS	M/M
L.T.	29
L.I.	20
H.T.	38
H.I.	30
O	4
E	11
T	5
CHARGE	KG
UTILE	150
RUPTURE	750

**FERMATURE PAR VISSAGE MANUEL ET COMPLET DE L' ECROU POUR GARANTIR UNE SECURITE OPTIMALE (AUCUN FILET NE DOIT ETRE APPARENT).**

**CONTROLE SYSTEMATIQUE DES MAILLONS AVANT CHAQUE VOL.**

## DONNEES TECHNIQUES FIL

### FABRICATION DE VOILE

NOM	SERAFIL
N° DE REFERENCE	60
MATERIEL	POLYESTER
FINITION	SILK
DENSITE LINEAIRE	NM 61 / 3 (DTEX 163 * 3)
CHARGE DE RUPTURE	3,000 CN
ALLONGEMENT	17 %

### PROPRIETE SERAFIL

SOLIDITE A LA LUMIERE ARTIFICIELLE	ISO 105 B02 > 5 - 6
SOLIDITE A LA SUEUR	ISO 105 E04 > 4
SOLIDITE AU LAVAGE	ISO 105 C04 > 3
SOLIDITE AU FROTTEMENT A SEC	ISO 105 X12 > 4
SOLIDITE AU LAVAGE EN SECHERESSE	ISO 105 D01 > 3 - 4

DEPERLANT	WR
-----------	----

### FABRICATION ELEVATEURS

NOM	COATS BONDED C.F.P.
N° DE REFERENCE	V138
MATERIEL	POLYESTER
FINITION	SILK
CHARGE DE RUPTURE	9,5 KG
ALLONGEMENT	19 %

**DONNEES TECHNIQUES SANGLES****ELEVATEURS**

REFERENCE	G-R 22
MATERIEL	POLYESTER
LARGEUR	22 M/M
EPAISSEUR	1,52 M/M
CHARGE DE RUPTURE	1,100 DAN
ALLONGEMENT	MAX. 15 %
POIDS	25 G* L.M.
COULEUR	NOIR

**INDICATEUR DE COULEUR**

REFERENCE	IC-G 1-2
MATERIEL	POLYESTER
LARGEUR	70 M/M
EPAISSEUR	0,80 M/M
CHARGE DE RUPTURE	130 DN
ALLONGEMENT	35%
POIDS	32 G * L.M.
COULEUR	VERT

**POINT D'ATTACHE**

REFERENCE	LKI - 10
MATERIEL	NYLON
LARGEUR	10 M/M
CHARGE DE RUPTURE	84 KG
ALLONGEMENT	30 %
POIDS	5,5 G/M
COULEUR	BLANC

**nIVIUK**

[niviuk.com](http://niviuk.com)

The importance of small details