

TECHNICAL SPECIFICATIONS



KOYOT

TECHNICAL DATA

KOYOT			22	24	26	28	31
CELLS	NUMBER		37	37	37	37	37
	CLOSED		4	4	4	4	4
	BOX		31	31	31	31	31
FLAT	AREA	M2	21,5	24	26	28	31
	SPAN	M	10,26	10,84	11,27	11,71	12,32
	ASPECT RATIO		4,9	4,9	4,9	4,9	4,9
PROJECTED	AREA	M2	18,31	20,41	22,58	23,76	26,27
	SPAN	M	8,1	8,54	9,13	9,2	9,66
	ASPECT RATIO		3,69	3,69	3,69	3,69	3,69
FLATTENING		%	15	15	15	15	15
CORD	MAXIMUM	M	2,55	2,69	2,8	2,9	3,06
	MINIMUM	M	0,59	0,63	0,65	0,67	0,71
	AVERAGE		2,09	2,21	2,3	2,39	2,51
LINES	TOTAL METERS	M	324	342	359	369	389
	HEIGHT	M	6,06	6,4	6,65	6,91	7,27
	NUMBER		244	244	244	244	244
	MAIN		3/4/3/3	3/4/3/3	3/4/3/3	3/4/3/3	3/4/3/3
RISERS	NUMBER	4	A/B/C/D	A/B/C/D	A/B/C/D	A/B/C/D	A/B/C/D
	TRIMS		NO	NO	NO	NO	NO
TOTAL WEIGHT	MINIMUM	KG	45	60	75	90	110
IN FLIGHT	MAXIMUM	KG	65	80	95	115	135
GLIDER WEIGHT		KG	5,05	5,3	5,6	5,9	6,3
CERTIFICATION	EN		B	B	B	B	A
	LTF		1	1	1	1	1

MATERIALS DESCRIPTION'S

CANOPY	FABRIC CODE	SUPPLIER
UPPER SURFACE	SKYTEX 45 9092 E85A	NCV (FRANCE)
BOTTOM SURFACE	SKYTEX 40 9017 E38A	NCV (FRANCE)
PROFILES	3RS FM	DOMINICO
DIAGONALS	3RS FM	DOMINICO
LOOPS	LKI - 10	KOLON INDUSTRIAL (KOREA)
REINFORCEMENT LOOPS	W-420	D-P (GERMANY)
TRAILING EDGE REINFORCEMENT	MYLAR 25 M/M	D-P (GERMANY)
RIBS REINFORCEMENTS	W-420	D-P (GERMANY)
THREAD	SERAFIL 40	AMAN (GERMANY)
SUSPENSION LINES	FABRIC CODE	SUPPLIER
UPPER CASCADES	TNL - 080	TEIJIN LIMITED (JAPAN)
MIDDLE CASCADES	TNL - 080	TEIJIN LIMITED (JAPAN)
MIDDLE CASCADES	TNL - 140	TEIJIN LIMITED (JAPAN)
MAIN	TNL - 140	TEIJIN LIMITED (JAPAN)
MAIN	TNL - 220	TEIJIN LIMITED (JAPAN)
MAIN	TNL - 280	TEIJIN LIMITED (JAPAN)
MAIN BREAK	TNL - 400	TEIJIN LIMITED (JAPAN)
THREAD	SERAFIL 60	AMAN (GERMANY)
RISERS	FABRIC CODE	SUPPLIER
MATERIAL	G-R 22	TECHNI SANGLES (FRANCE)
COLOR INDICATOR	PAD	TECHNI SANGLES (FRANCE)
THREAD	N/F-66	YOUNG CHANG T&C LTD
MAILLONS	MRI4	ANSUNG PRECISION (KOREA)
PULLEYS	PY-1304 - 2	ANSUNG PRECISION (KOREA)

SUSPENSION PLAN

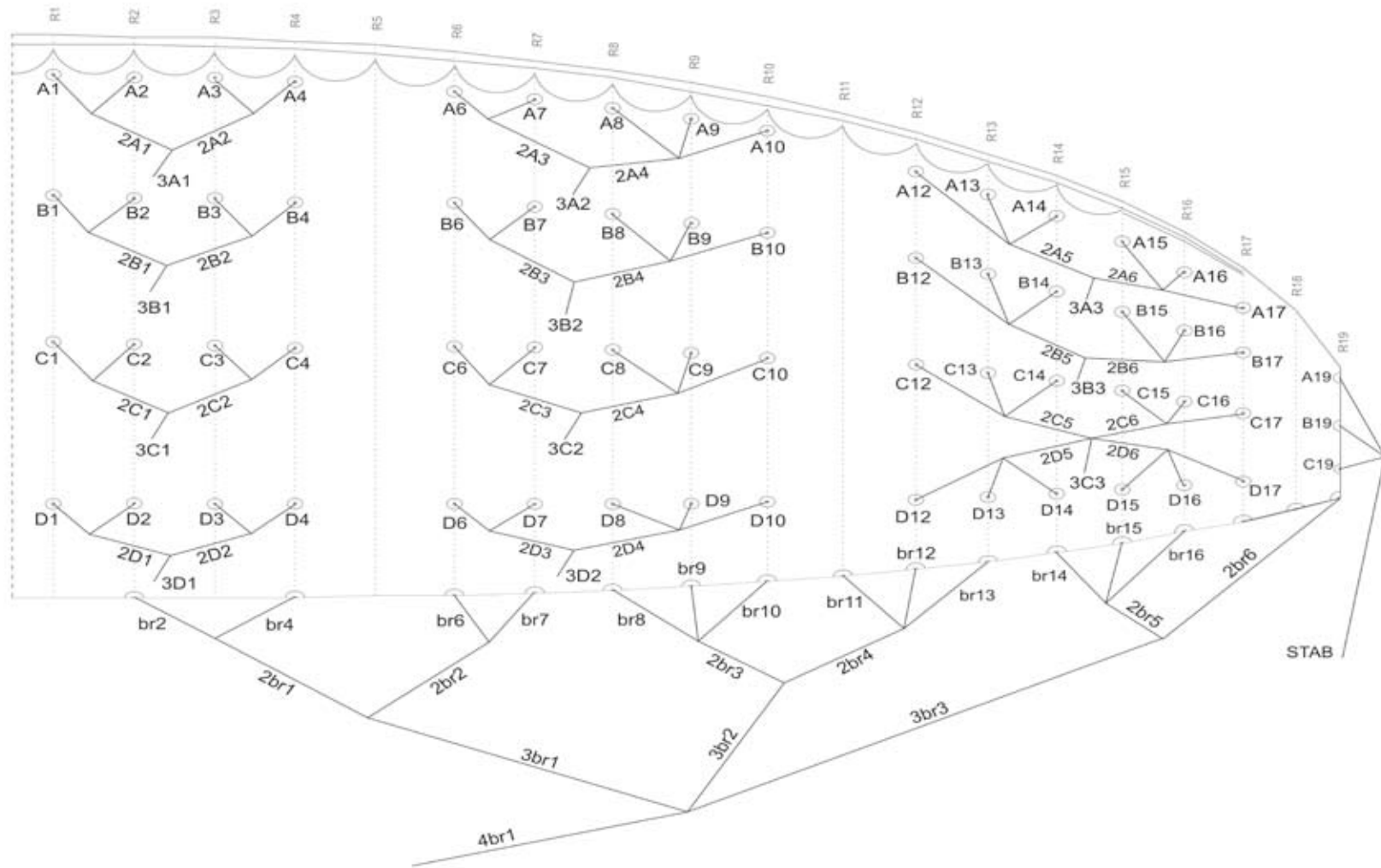

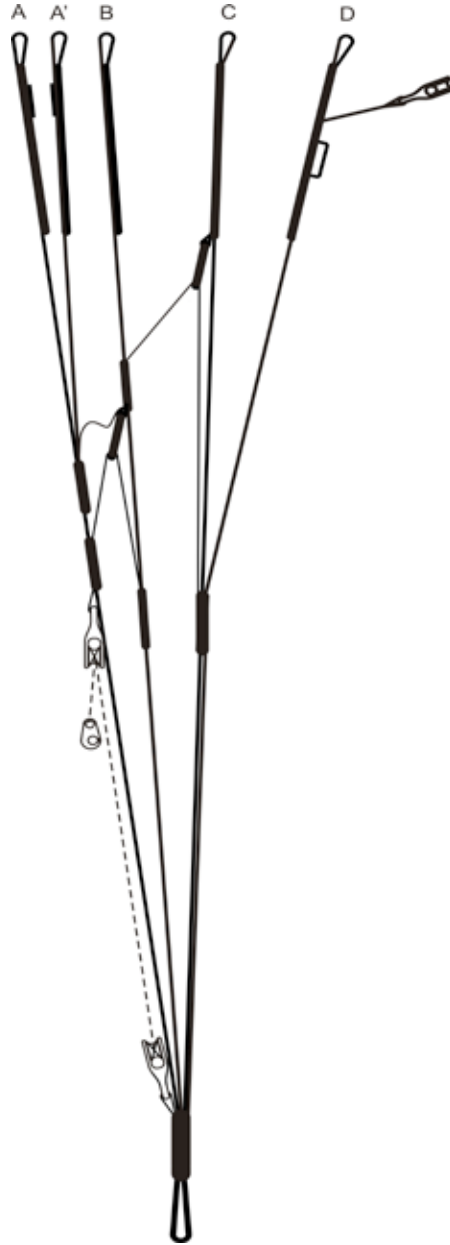

COLORS TECHNICAL DATA

BOBY	1	GREEN	TOP COLOR	REF: 551
	4	GREEN	BOTTOM COLOR	REF: 551
	2	SUNFLOWER	HORN	REF: 921
	3	DRAGON RED	SHADOW	REF: 636



SPICY	1	DRAGON RED	TOP COLOR	REF: 636
	4	DRAGON RED	BOTTOM COLOR	REF: 636
	2	DARK RED	HORN	REF: 615
	3	WHITE	SHADOW	REF: 001

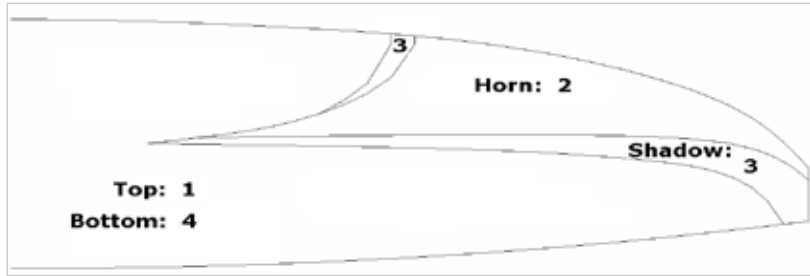

SUNNY	1	ORANGE	TOP COLOR	REF: 744
	4	ORANGE	BOTTOM COLOR	REF: 744
	2	DARK GREY	HORN	REF: 121
	3	WHITE	SHADOW	REF: 001



AZUR	1	DEEP BLUE	TOP COLOR	REF: 354
	4	DEEP BLUE	BOTTOM COLOR	REF: 354
	2	SUNFLOWER	HORN	REF: 921
	3	ORANGE	SHADOW	REF: 744



WING LOAD TECHNICAL DATA

KOYOT	31		28		26		24		22	
	P.T.V.	KG/M2	P.T.V.	KG/M2	P.T.V.	KG/M2	P.T.V.	KG/M2	P.T.V.	KG/M2
	135	= 4,35	115	= 4,11	95	= 3,65	85	= 3,54	65	= 2,95
	134	= 4,32	114	= 4,07	94	= 3,62	84	= 3,50	64	= 2,91
	133	= 4,29	113	= 4,04	93	= 3,58	83	= 3,46	63	= 2,86
	132	= 4,26	112	= 4	92	= 3,54	82	= 3,42	62	= 2,82
	131	= 4,23	111	= 3,96	91	= 3,50	81	= 3,38	61	= 2,77
	130	= 4,19	110	= 3,93	90	= 3,46	80	= 3,33	60	= 2,73
	129	= 4,16	109	= 3,89	89	= 3,42	79	= 3,29	59	= 2,68
	128	= 4,13	108	= 3,86	88	= 3,38	78	= 3,25	58	= 2,64
	127	= 4,10	107	= 3,82	87	= 3,35	77	= 3,21	57	= 2,59
	126	= 4,06	106	= 3,79	86	= 3,31	76	= 3,17	56	= 2,55
	125	= 4,03	105	= 3,75	85	= 3,27	75	= 3,13	55	= 2,50
	124	= 4	104	= 3,71	84	= 3,23	74	= 3,08	54	= 2,45
	123	= 3,97	103	= 3,68	83	= 3,19	73	= 3,04	53	= 2,41
	122	= 3,94	102	= 3,64	82	= 3,15	72	= 3	52	= 2,36
	121	= 3,90	101	= 3,61	81	= 3,12	71	= 2,96	51	= 2,32
	120	= 3,87	100	= 3,57	80	= 3,08	70	= 2,92	50	= 2,27
	119	= 3,84	99	= 3,54	79	= 3,04	69	= 2,88	49	= 2,23
	118	= 3,81	98	= 3,50	78	= 3	68	= 2,83	48	= 2,18
	117	= 3,77	97	= 3,46	77	= 2,96	67	= 2,79	47	= 2,14
	116	= 3,74	96	= 3,43	76	= 2,92	66	= 2,75	46	= 2,09
	115	= 3,71	95	= 3,39	75	= 2,88	65	= 2,71	45	= 2,05
	114	= 3,68	94	= 3,36			64	= 2,67		
	113	= 3,65	93	= 3,32			63	= 2,63		
	112	= 3,61	92	= 3,29			62	= 2,58		
	111	= 3,58	91	= 3,25			61	= 2,54		
	110	= 3,55	90	= 3,21			60	= 2,50		

LINES TECHNICAL DATA

KOYOT 22

REF.	CODE	CM.	REF.	CODE	CM.	REF.	CODE	CM.	REF.	CODE	CM.	REF.	CODE	
A			B			C			D			BRAKE		
A1	TNL-080-YLW	89,5	B1	TNL-080-BLU	89,5	C1	TNL-080-BLU	72,5	D1	TNL-080-BLU	53,5	BR2	TNL-080-PNK	112,5
A2	TNL-080-YLW	85,5	B2	TNL-080-BLU	85,5	C2	TNL-080-BLU	67	D2	TNL-080-BLU	47	BR4	TNL-080-PNK	87
A3	TNL-080-YLW	86,5	B3	TNL-080-BLU	86	C3	TNL-080-BLU	68	D3	TNL-080-BLU	48,5	BR6	TNL-080-PNK	45
A4	TNL-080-YLW	88,5	B4	TNL-080-BLU	88	C4	TNL-080-BLU	71,5	D4	TNL-080-BLU	53	BR7	TNL-080-PNK	42,5
A6	TNL-080-YLW	88	B6	TNL-080-BLU	87,5	C6	TNL-080-BLU	71	D6	TNL-080-BLU	52,5	BR8	TNL-080-PNK	87,5
A7	TNL-080-YLW	84	B7	TNL-080-BLU	83,5	C7	TNL-080-BLU	65,5	D7	TNL-080-BLU	44,5	BR9	TNL-080-PNK	77
A8	TNL-080-YLW	169,5	B8	TNL-080-BLU	167	C8	TNL-080-BLU	131,5	D8	TNL-080-BLU	92	BR10	TNL-080-PNK	76,5
A9	TNL-080-YLW	169	B9	TNL-080-BLU	167	C9	TNL-080-BLU	132	D9	TNL-080-BLU	93	BR11	TNL-080-PNK	73
A10	TNL-080-YLW	172	B10	TNL-080-BLU	170,5	C10	TNL-080-BLU	137,5	D10	TNL-080-BLU	101	BR12	TNL-080-PNK	73,5
A12	TNL-080-YLW	160	B12	TNL-080-BLU	155	C12	TNL-080-BLU	133,5	D12	TNL-080-BLU	90,5	BR13	TNL-080-PNK	81,5
A13	TNL-080-YLW	155	B13	TNL-080-BLU	150,5	C13	TNL-080-BLU	128	D13	TNL-080-BLU	84	BR14	TNL-080-PNK	59
A14	TNL-080-YLW	152	B14	TNL-080-BLU	148	C14	TNL-080-BLU	125,5	D14	TNL-080-BLU	82,5	BR15	TNL-080-PNK	52
A15	TNL-080-YLW	150	B15	TNL-080-BLU	139	C15	TNL-080-BLU	115	D15	TNL-080-BLU	77	BR16	TNL-080-PNK	52
A16	TNL-080-YLW	145,5	B16	TNL-080-BLU	135	C16	TNL-080-BLU	111,5	D16	TNL-080-BLU	72			
A17	TNL-080-YLW	142,5	B17	TNL-080-BLU	132	C17	TNL-080-BLU	109	D17	TNL-080-BLU	71			
A19	TNL-080-RED	129,5	B19	TNL-080-RED	128	C19	TNL-080-RED	130,5						
2 A1	TNL-140-YLW	109,5	2 B1	TNL-140-BLU	109	2 C1	TNL-140-BLU	85,5	2 D1	TNL-140-BLU	84,5	2 BR1	TNL-080-PNK	139,5
2 A2	TNL-140-YLW	107,5	2 B2	TNL-140-BLU	107	2 C2	TNL-140-BLU	83,5	2 D2	TNL-140-BLU	82	2 BR2	TNL-080-PNK	161,5
2 A3	TNL-140-YLW	153	2 B3	TNL-140-BLU	151,5	2 C3	TNL-140-BLU	118,5	2 D3	TNL-140-BLU	89,5	2 BR3	TNL-080-PNK	93
2 A4	TNL-140-YLW	65	2 B4	TNL-140-BLU	65,5	2 C4	TNL-140-BLU	50	2 D4	TNL-140-BLU	38,5	2 BR4	TNL-080-PNK	96
2 A5	TNL-140-YLW	84,5	2 B5	TNL-140-BLU	78	2 C5	TNL-140-BLU	62,5	2 D5	TNL-140-BLU	115	2 BR5	TNL-080-PNK	65,5
2 A6	TNL-140-YLW	81,5	2 B6	TNL-140-BLU	83	2 C6	TNL-140-BLU	69	2 D6	TNL-140-BLU	115	2 BR6	TNL-080-PNK	115
3 A1	TNL-280-YLW	403	3 B1	TNL-280-BLU	396	3 C1	TNL-280-BLU	440	3 D1	TNL-220-BLU	471,5	3 BR1	TNL-140-PNK	245
3 A2	TNL-220-YLW	355	3 B2	TNL-220-BLU	351	3 C2	TNL-220-BLU	404	3 D2	TNL-220-BLU	465	3 BR2	TNL-140-PNK	263,5
3 A3	TNL-220-YLW	342,5	3 B3	TNL-220-BLU	350	3 C3	TNL-220-BLU	390,5				3 BR3	TNL-140-PNK	305
			STAB	TNL-140-PNK	410							4 BR1	TNL-400-PNK	206,5
												POINT AT:		186,5

LINES TECHNICAL DATA

KOYOT 24

REF.	CODE	CM.	REF.	CODE	CM.	REF.	CODE	CM.	REF.	CODE	CM.	REF.	CODE	
A			B			C			D			BRAKE		
A1	TNL-080-YLW	94,5	B1	TNL-080-BLU	94,5	C1	TNL-080-BLU	76,5	D1	TNL-080-BLU	56,5	BR2	TNL-080-PNK	119
A2	TNL-080-YLW	90	B2	TNL-080-BLU	90	C2	TNL-080-BLU	71	D2	TNL-080-BLU	50	BR4	TNL-080-PNK	91,5
A3	TNL-080-YLW	91	B3	TNL-080-BLU	91	C3	TNL-080-BLU	72	D3	TNL-080-BLU	51	BR6	TNL-080-PNK	47,5
A4	TNL-080-YLW	93,5	B4	TNL-080-BLU	93	C4	TNL-080-BLU	75,5	D4	TNL-080-BLU	56	BR7	TNL-080-PNK	45
A6	TNL-080-YLW	93	B6	TNL-080-BLU	92,5	C6	TNL-080-BLU	75	D6	TNL-080-BLU	55,5	BR8	TNL-080-PNK	92,5
A7	TNL-080-YLW	88,5	B7	TNL-080-BLU	88,5	C7	TNL-080-BLU	69,5	D7	TNL-080-BLU	47,5	BR9	TNL-080-PNK	81,5
A8	TNL-080-YLW	179	B8	TNL-080-BLU	176,5	C8	TNL-080-BLU	139	D8	TNL-080-BLU	97,5	BR10	TNL-080-PNK	80,5
A9	TNL-080-YLW	178,5	B9	TNL-080-BLU	176,5	C9	TNL-080-BLU	139,5	D9	TNL-080-BLU	98	BR11	TNL-080-PNK	77
A10	TNL-080-YLW	182	B10	TNL-080-BLU	180	C10	TNL-080-BLU	145	D10	TNL-080-BLU	107	BR12	TNL-080-PNK	77,5
A12	TNL-080-YLW	169	B12	TNL-080-BLU	163,5	C12	TNL-080-BLU	141	D12	TNL-080-BLU	95,5	BR13	TNL-080-PNK	86
A13	TNL-080-YLW	163,5	B13	TNL-080-BLU	159	C13	TNL-080-BLU	135,5	D13	TNL-080-BLU	88,5	BR14	TNL-080-PNK	62,5
A14	TNL-080-YLW	160,5	B14	TNL-080-BLU	156	C14	TNL-080-BLU	132,5	D14	TNL-080-BLU	87,5	BR15	TNL-080-PNK	55
A15	TNL-080-YLW	158,5	B15	TNL-080-BLU	146,5	C15	TNL-080-BLU	121,5	D15	TNL-080-BLU	81	BR16	TNL-080-PNK	55
A16	TNL-080-YLW	153,5	B16	TNL-080-BLU	142,5	C16	TNL-080-BLU	117,5	D16	TNL-080-BLU	76			
A17	TNL-080-YLW	150,5	B17	TNL-080-BLU	139,5	C17	TNL-080-BLU	115,5	D17	TNL-080-BLU	75			
A19	TNL-080-RED	137	B19	TNL-080-RED	135,5	C19	TNL-080-RED	137,5						
2 A1	TNL-140-YLW	115,5	2 B1	TNL-140-BLU	115	2 C1	TNL-140-BLU	90,5	2 D1	TNL-140-BLU	89,5	2 BR1	TNL-080-PNK	147,5
2 A2	TNL-140-YLW	113,5	2 B2	TNL-140-BLU	113	2 C2	TNL-140-BLU	88	2 D2	TNL-140-BLU	87	2 BR2	TNL-080-PNK	170,5
2 A3	TNL-140-YLW	162	2 B3	TNL-140-BLU	160	2 C3	TNL-140-BLU	125	2 D3	TNL-140-BLU	94,5	2 BR3	TNL-080-PNK	278
2 A4	TNL-140-YLW	68,5	2 B4	TNL-140-BLU	69,5	2 C4	TNL-140-BLU	52,5	2 D4	TNL-140-BLU	40,5	2 BR4	TNL-080-PNK	101
2 A5	TNL-140-YLW	89	2 B5	TNL-140-BLU	82,5	2 C5	TNL-140-BLU	66	2 D5	TNL-140-BLU	121,5	2 BR5	TNL-080-PNK	68,5
2 A6	TNL-140-YLW	86	2 B6	TNL-140-BLU	87,5	2 C6	TNL-140-BLU	73	2 D6	TNL-140-BLU	121,5	2 BR6	TNL-080-PNK	120
3 A1	TNL-280-YLW	425,5	3 B1	TNL-280-BLU	418,5	3 C1	TNL-280-BLU	464,5	3 D1	TNL-220-BLU	498,5	3 BR1	TNL-140-PNK	258,5
3 A2	TNL-220-YLW	375,5	3 B2	TNL-220-BLU	370,5	3 C2	TNL-220-BLU	427	3 D2	TNL-220-BLU	491,5	3 BR2	TNL-140-PNK	278
3 A3	TNL-220-YLW	362	3 B3	TNL-220-BLU	370	3 C3	TNL-220-BLU	413				3 BR3	TNL-140-PNK	322,5
			STAB	TNL-140-PNK	433							4 BR1	TNL-400-PNK	215,5
													POINT AT:	195,5

LINES TECHNICAL DATA

KOYOT 26

REF.	CODE	CM.	REF.	CODE	CM.	REF.	CODE	CM.	REF.	CODE	CM.	REF.	CODE
A			B			C			D			BRAKE	
A1	TNL-080-YLW	98,5	B1	TNL-080-BLU	98,5	C1	TNL-080-BLU	80	D1	TNL-080-BLU	59	BR2	TNL-080-PNK 124,5
A2	TNL-080-YLW	94	B2	TNL-080-BLU	93,5	C2	TNL-080-BLU	74	D2	TNL-080-BLU	52	BR4	TNL-080-PNK 95,5
A3	TNL-080-YLW	95	B3	TNL-080-BLU	94,5	C3	TNL-080-BLU	75	D3	TNL-080-BLU	53	BR6	TNL-080-PNK 49,5
A4	TNL-080-YLW	97	B4	TNL-080-BLU	97	C4	TNL-080-BLU	78,5	D4	TNL-080-BLU	58	BR7	TNL-080-PNK 47
A6	TNL-080-YLW	97	B6	TNL-080-BLU	96,5	C6	TNL-080-BLU	78	D6	TNL-080-BLU	58	BR8	TNL-080-PNK 96,5
A7	TNL-080-YLW	92	B7	TNL-080-BLU	92	C7	TNL-080-BLU	72	D7	TNL-080-BLU	49	BR9	TNL-080-PNK 85
A8	TNL-080-YLW	186,5	B8	TNL-080-BLU	183,5	C8	TNL-080-BLU	144	D8	TNL-080-BLU	100	BR10	TNL-080-PNK 84
A9	TNL-080-YLW	186	B9	TNL-080-BLU	183,5	C9	TNL-080-BLU	145	D9	TNL-080-BLU	102	BR11	TNL-080-PNK 80
A10	TNL-080-YLW	189	B10	TNL-080-BLU	187,5	C10	TNL-080-BLU	151	D10	TNL-080-BLU	111,5	BR12	TNL-080-PNK 81
A12	TNL-080-YLW	176	B12	TNL-080-BLU	170,5	C12	TNL-080-BLU	147	D12	TNL-080-BLU	99,5	BR13	TNL-080-PNK 89,5
A13	TNL-080-YLW	170,5	B13	TNL-080-BLU	165,5	C13	TNL-080-BLU	141	D13	TNL-080-BLU	92,5	BR14	TNL-080-PNK 65
A14	TNL-080-YLW	167	B14	TNL-080-BLU	162,5	C14	TNL-080-BLU	138	D14	TNL-080-BLU	91	BR15	TNL-080-PNK 57,5
A15	TNL-080-YLW	165	B15	TNL-080-BLU	152,5	C15	TNL-080-BLU	162,5	D15	TNL-080-BLU	84,5	BR16	TNL-080-PNK 57
A16	TNL-080-YLW	160	B16	TNL-080-BLU	148,5	C16	TNL-080-BLU	122,5	D16	TNL-080-BLU	79,5		
A17	TNL-080-YLW	157	B17	TNL-080-BLU	145,5	C17	TNL-080-BLU	120,5	D17	TNL-080-BLU	78,5		
A19	TNL-080-RED	76,5	B19	TNL-080-RED	75,5	C19	TNL-080-RED	84					
2 A1	TNL-140-YLW	120	2 B1	TNL-140-BLU	120	2 C1	TNL-140-BLU	94	2 D1	TNL-140-BLU	93	2 BR1	TNL-080-PNK 154
2 A2	TNL-140-YLW	118	2 B2	TNL-140-BLU	118	2 C2	TNL-140-BLU	92	2 D2	TNL-140-BLU	90,5	2 BR2	TNL-080-PNK 177,5
2 A3	TNL-140-YLW	168,5	2 B3	TNL-140-BLU	166	2 C3	TNL-140-BLU	129,5	2 D3	TNL-140-BLU	97	2 BR3	TNL-080-PNK 102
2 A4	TNL-140-YLW	71,5	2 B4	TNL-140-BLU	72,5	2 C4	TNL-140-BLU	55	2 D4	TNL-140-BLU	42	2 BR4	TNL-080-PNK 105,5
2 A5	TNL-140-YLW	92,5	2 B5	TNL-140-BLU	85,5	2 C5	TNL-140-BLU	68,5	2 D5	TNL-140-BLU	126,0	2 BR5	TNL-080-PNK 71,5
2 A6	TNL-140-YLW	90	2 B6	TNL-140-BLU	91,5	2 C6	TNL-140-BLU	75,5	2 D6	TNL-140-BLU	125,5	2 BR6	TNL-080-PNK 120,5
3 A1	TNL-280-YLW	442	3 B1	TNL-280-BLU	434,5	3 C1	TNL-280-BLU	482,5	3 D1	TNL-220-BLU	517,5	3 BR1	TNL-140-PNK 269
3 A2	TNL-220-YLW	390	3 B2	TNL-220-BLU	385,5	3 C2	TNL-220-BLU	445	3 D2	TNL-220-BLU	512,5	3 BR2	TNL-140-PNK 289,5
3 A3	TNL-220-YLW	376,5	3 B3	TNL-220-BLU	385	3 C3	TNL-220-BLU	429				3 BR3	TNL-140-PNK 335,5
			STAB	TNL-140-PNK	516							4 BR1	TNL-400-PNK 223,5
												POINT AT:	203,5

LINES TECHNICAL DATA

KOYOT			28											
REF.	CODE	CM.	REF.	CODE	CM.	REF.	CODE	CM.	REF.	CODE	CM.	REF.	CODE	
A			B			C			D			BRAKE		
A1	TNL-080-YLW	102	B1	TNL-080-BLU	102	C1	TNL-080-BLU	83	D1	TNL-080-BLU	61	BR2	TNL-080-PNK	129,5
A2	TNL-080-YLW	97,5	B2	TNL-080-BLU	97	C2	TNL-080-BLU	76,5	D2	TNL-080-BLU	54	BR4	TNL-080-PNK	99
A3	TNL-080-YLW	98,5	B3	TNL-080-BLU	98	C3	TNL-080-BLU	78	D3	TNL-080-BLU	55	BR6	TNL-080-PNK	51
A4	TNL-080-YLW	101	B4	TNL-080-BLU	100,5	C4	TNL-080-BLU	81,5	D4	TNL-080-BLU	60	BR7	TNL-080-PNK	48,5
A6	TNL-080-YLW	100,5	B6	TNL-080-BLU	100	C6	TNL-080-BLU	81	D6	TNL-080-BLU	60	BR8	TNL-080-PNK	100
A7	TNL-080-YLW	95,5	B7	TNL-080-BLU	95,5	C7	TNL-080-BLU	75	D7	TNL-080-BLU	51	BR9	TNL-080-PNK	88
A8	TNL-080-YLW	193,5	B8	TNL-080-BLU	191	C8	TNL-080-BLU	150	D8	TNL-080-BLU	105	BR10	TNL-080-PNK	87
A9	TNL-080-YLW	193	B9	TNL-080-BLU	190,5	C9	TNL-080-BLU	150,5	D9	TNL-080-BLU	106	BR11	TNL-080-PNK	83
A10	TNL-080-YLW	196,5	B10	TNL-080-BLU	194,5	C10	TNL-080-BLU	156,5	D10	TNL-080-BLU	115,5	BR12	TNL-080-PNK	84
A12	TNL-080-YLW	183	B12	TNL-080-BLU	177	C12	TNL-080-BLU	152,5	D12	TNL-080-BLU	103,5	BR13	TNL-080-PNK	93
A13	TNL-080-YLW	177	B13	TNL-080-BLU	171,5	C13	TNL-080-BLU	146,5	D13	TNL-080-BLU	96	BR14	TNL-080-PNK	67,5
A14	TNL-080-YLW	173,5	B14	TNL-080-BLU	168,5	C14	TNL-080-BLU	143	D14	TNL-080-BLU	94,5	BR15	TNL-080-PNK	59,5
A15	TNL-080-YLW	171	B15	TNL-080-BLU	158,5	C15	TNL-080-BLU	131,5	D15	TNL-080-BLU	87,5	BR16	TNL-080-PNK	59
A16	TNL-080-YLW	166	B16	TNL-080-BLU	154	C16	TNL-080-BLU	127	D16	TNL-080-BLU	82,5			
A17	TNL-080-YLW	162,5	B17	TNL-080-BLU	150,5	C17	TNL-080-BLU	124,5	D17	TNL-080-BLU	81			
A19	TNL-080-RED	149	B19	TNL-080-RED	146,5	C19	TNL-080-RED	148,5						
2 A1	TNL-140-YLW	125	2 B1	TNL-140-BLU	124,5	2 C1	TNL-140-BLU	98	2 D1	TNL-140-BLU	96,5	2 BR1	TNL-080-PNK	160
2 A2	TNL-140-YLW	122,5	2 B2	TNL-140-BLU	122	2 C2	TNL-140-BLU	95,5	2 D2	TNL-140-BLU	94	2 BR2	TNL-080-PNK	184
2 A3	TNL-140-YLW	175	2 B3	TNL-140-BLU	172,5	2 C3	TNL-140-BLU	135	2 D3	TNL-140-BLU	102	2 BR3	TNL-080-PNK	106
2 A4	TNL-140-YLW	74	2 B4	TNL-140-BLU	75	2 C4	TNL-140-BLU	57	2 D4	TNL-140-BLU	44	2 BR4	TNL-080-PNK	109,5
2 A5	TNL-140-YLW	96	2 B5	TNL-140-BLU	89	2 C5	TNL-140-BLU	71,5	2 D5	TNL-140-BLU	131,5	2 BR5	TNL-080-PNK	73,5
2 A6	TNL-140-YLW	93	2 B6	TNL-140-BLU	94,5	2 C6	TNL-140-BLU	78,5	2 D6	TNL-140-BLU	131,5	2 BR6	TNL-080-PNK	130
3 A1	TNL-280-YLW	460	3 B1	TNL-280-BLU	452,5	3 C1	TNL-280-BLU	502	3 D1	TNL-220-BLU	538,5	3 BR1	TNL-140-PNK	278,5
3 A2	TNL-220-YLW	405,5	3 B2	TNL-220-BLU	400,5	3 C2	TNL-220-BLU	461,5	3 D2	TNL-220-BLU	531	3 BR2	TNL-140-PNK	300
3 A3	TNL-220-YLW	391	3 B3	TNL-220-BLU	400	3 C3	TNL-220-BLU	446				3 BR3	TNL-140-PNK	348,5
			STAB	TNL-140-PNK	467,5							4 BR1	TNL-400-PNK	229,5
													POINT AT:	209,5

LINES TECHNICAL DATA

KOYOT 31

REF.	CODE	CM.	REF.	CODE	CM.	REF.	CODE	CM.	REF.	CODE	CM.	REF.	CODE	
A			B			C			D			BRAKE		
A1	TNL-080-YLW	107,5	B1	TNL-080-BLU	107	C1	TNL-080-BLU	87	D1	TNL-080-BLU	64,5	BR2	TNL-080-PNK	136,5
A2	TNL-080-YLW	102,5	B2	TNL-080-BLU	102	C2	TNL-080-BLU	80,5	D2	TNL-080-BLU	56,5	BR4	TNL-080-PNK	104
A3	TNL-080-YLW	103,5	B3	TNL-080-BLU	103	C3	TNL-080-BLU	82	D3	TNL-080-BLU	58	BR6	TNL-080-PNK	54
A4	TNL-080-YLW	106	B4	TNL-080-BLU	106	C4	TNL-080-BLU	86	D4	TNL-080-BLU	63,5	BR7	TNL-080-PNK	51
A6	TNL-080-YLW	106	B6	TNL-080-BLU	105	C6	TNL-080-BLU	85	D6	TNL-080-BLU	63	BR8	TNL-080-PNK	105
A7	TNL-080-YLW	100,5	B7	TNL-080-BLU	100,5	C7	TNL-080-BLU	78,5	D7	TNL-080-BLU	53,5	BR9	TNL-080-PNK	92,5
A8	TNL-080-YLW	203,5	B8	TNL-080-BLU	200,5	C8	TNL-080-BLU	158	D8	TNL-080-BLU	110,5	BR10	TNL-080-PNK	92
A9	TNL-080-YLW	203	B9	TNL-080-BLU	200,5	C9	TNL-080-BLU	158,5	D9	TNL-080-BLU	111,5	BR11	TNL-080-PNK	87,5
A10	TNL-080-YLW	206,5	B10	TNL-080-BLU	205	C10	TNL-080-BLU	165	D10	TNL-080-BLU	121,5	BR12	TNL-080-PNK	88,5
A12	TNL-080-YLW	192,5	B12	TNL-080-BLU	186	C12	TNL-080-BLU	160,5	D12	TNL-080-BLU	108,5	BR13	TNL-080-PNK	98
A13	TNL-080-YLW	186	B13	TNL-080-BLU	180,5	C13	TNL-080-BLU	154	D13	TNL-080-BLU	101	BR14	TNL-080-PNK	71
A14	TNL-080-YLW	182,5	B14	TNL-080-BLU	177,5	C14	TNL-080-BLU	150,5	D14	TNL-080-BLU	99,5	BR15	TNL-080-PNK	62,5
A15	TNL-080-YLW	180	B15	TNL-080-BLU	166,5	C15	TNL-080-BLU	138	D15	TNL-080-BLU	92	BR16	TNL-080-PNK	62,5
A16	TNL-080-YLW	174,5	B16	TNL-080-BLU	162	C16	TNL-080-BLU	134	D16	TNL-080-BLU	86,5			
A17	TNL-080-YLW	171	B17	TNL-080-BLU	158,5	C17	TNL-080-BLU	131	D17	TNL-080-BLU	85,5			
A19	TNL-080-RED	157	B19	TNL-080-RED	154	C19	TNL-080-RED	155,5						
2 A1	TNL-140-YLW	131,5	2 B1	TNL-140-BLU	131	2 C1	TNL-140-BLU	103	2 D1	TNL-140-BLU	101,5	2 BR1	TNL-080-PNK	168,5
2 A2	TNL-140-YLW	129	2 B2	TNL-140-BLU	128,5	2 C2	TNL-140-BLU	100,5	2 D2	TNL-140-BLU	98,5	2 BR2	TNL-080-PNK	194
2 A3	TNL-140-YLW	184	2 B3	TNL-140-BLU	182	2 C3	TNL-140-BLU	142	2 D3	TNL-140-BLU	107	2 BR3	TNL-080-PNK	111,5
2 A4	TNL-140-YLW	78	2 B4	TNL-140-BLU	79	2 C4	TNL-140-BLU	60	2 D4	TNL-140-BLU	46	2 BR4	TNL-080-PNK	115
2 A5	TNL-140-YLW	101	2 B5	TNL-140-BLU	93,5	2 C5	TNL-140-BLU	75	2 D5	TNL-140-BLU	138	2 BR5	TNL-080-PNK	77
2 A6	TNL-140-YLW	97,5	2 B6	TNL-140-BLU	99,5	2 C6	TNL-140-BLU	83	2 D6	TNL-140-BLU	138,5	2 BR6	TNL-080-PNK	137
3 A1	TNL-280-YLW	484	3 B1	TNL-280-BLU	476	3 C1	TNL-280-BLU	528,5	3 D1	TNL-220-BLU	567	3 BR1	TNL-140-PNK	293
3 A2	TNL-220-YLW	427	3 B2	TNL-220-BLU	421,5	3 C2	TNL-220-BLU	486	3 D2	TNL-220-BLU	559	3 BR2	TNL-140-PNK	315,5
3 A3	TNL-220-YLW	412	3 B3	TNL-220-BLU	421	3 C3	TNL-220-BLU	469,5				3 BR3	TNL-140-PNK	367
			STAB	TNL-140-PNK	492							4 BR1	TNL-400-PNK	240,5
													POINT AT:	220,5

NIVIUK KOYOT 22

LINES HEIGHT CM.						
	TA	B	C	D	RIB	BR
1	598	590,5	594	605,5	2	680,5
2	594	586,5	588,5	598,5	4	655
3	592,5	584,5	587	597,5	6	634,5
4	594,5	586,5	590,5	602	7	632
6	592	585,5	589,5	602,5	8	627
7	588	581,5	583,5	594,5	9	616,5
8	585,5	579	581	591	10	616
9	585	579	581,5	592	11	615
10	588	582,5	587	599,5	12	616
12	583	579	582	591,5	13	623,5
13	577,5	574,5	576,5	585	14	612
14	574,5	571,5	574	583	15	605
15	569,5	567,5	570	578	16	605
16	565	563,5	566,5	572,5	17	609,5
17	562	560,5	563,5	571,5		
STB	537	535,5	538			

RISERS LENGTHS CM.					
	A	B	C	D	
	47	47	47	47	STANDARD
	36,5	39	43	47	ACCELERATED

NIVIUK KOYOT 24

LINES HEIGHT CM.						
	A	B	C	D	RIB	BR
1	632,5	625	628,5	642	2	718,5
2	628,5	620,5	622,5	635	4	690,5
3	626,5	619,5	621,5	633,5	6	669,5
4	629,5	621,5	625	638,5	7	667
6	628	620	623,5	638,5	8	661
7	623	616	618,5	630,5	9	650
8	620,5	613,5	615,5	626,5	10	649,5
9	620	613,5	616	626,5	11	648,5
10	623,5	617	621,5	635,5	12	649
12	617,5	613	617	626,5	13	657,5
13	611,5	608	611	619,5	14	646
14	608,5	605,5	608,5	618,5	15	638,5
15	603,5	601	604	612	16	638,5
16	598,5	597	600	607	17	632,5
17	595,5	594	598	606		
STB	568,5	567,5	569,5			

RISERS LENGTHS CM.					
	A	B	C	D	
	47	47	47	47	STANDARD
	36	38	42	47	ACCELERATED

NIVIUK KOYOT 26

LINES HEIGHT CM.						
	A	B	C	D	RIB	BR
1	658,5	650,5	654	667	2	755
2	653,5	645,5	648	660	4	725,5
3	652,5	644,5	646,5	658,5	6	702,5
4	654,5	647	650	663,5	7	700
6	653,5	645,5	649,5	664,5	8	693,5
7	648,5	641	643,5	655,5	9	682,5
8	646	639	641,5	652,5	10	681
9	645,5	638,5	642	653,5	11	681
10	648,5	642,5	648	663,5	12	682
12	643	638	642	652	13	690,5
13	637,5	633,5	636	645	14	678
14	634	630	633	643,5	15	670,5
15	629	626	628,5	637	16	669,5
16	624	622	624,5	632	17	662,5
17	621	619	622,5	630,5		
STB	591,5	590,5	599,5			

RISERS LENGTHS CM.					
	A	B	C	D	
	47	47	47	47	STANDARD
	36	38	42	47	ACCELERATED

NIVIUK KOYOT 28

LINES HEIGHT CM.						
	A	B	C	D	RIB	BR
1	684	675,5	680	692	2	774,5
2	679,5	670,5	673	685,5	4	744
3	678	669,5	672,5	684	6	719,5
4	680,5	672	676	689	7	717,5
6	678	669,5	674	689,5	8	712,5
7	673	665,5	668,5	680,5	9	700
8	670,5	663,5	665,5	676,5	10	699
9	669,5	663	666	677,5	11	698,5
10	673,5	667	672	687	12	700
12	667	663	666,5	677,5	13	709
13	661	657,5	660,5	670	14	695,5
14	658	654,5	657	668,5	15	687,5
15	652	650	652,5	661,5	16	687
16	647	645,5	648	656,5	17	682
17	643,5	642	645,5	654,5		
STB	614,5	612,5	614,5			

RISERS LENGTHS CM.					
	A	B	C	D	
	47	47	47	47	STANDARD
	36	38	42	47	ACCELERATED

LINES HEIGHT CM.

	A	B	C	D	RIB	BR
1	719	709,5	714	728,5	2	816
2	714	704	707,5	720,5	4	783,5
3	712,5	703	706,5	718,5	6	759
4	715	706	710,5	724,5	7	755,5
6	713	704,5	709	724,5	8	749,5
7	707,5	700	702,5	715	9	737
8	705	697	699,5	711	10	736,5
9	704	697	700,5	711,5	11	735,5
10	707,5	701,5	706,5	722	12	736,5
12	701	696,5	700,5	711,5	13	745,5
13	694,5	691,5	694	703,5	14	732
14	691	687,5	690,5	702	15	724
15	685	682,5	686	695	16	723,5
16	679,5	678	681,5	689,5	17	724
17	675,5	674,5	678,5	688		
STB	646,5	643,5	644,5			

RISERS LENGTHS CM.

	A	B	C	D	
	47	47	47	47	STANDARD
	36	38	42	47	ACCELERATED

FABRIC TECHNICAL DATA UPPER SURFACE
DESCRIPTION

SKYTEX 45 EVOLUTION	REF. : F09092 - E85A
FABRIC	9092
TYPE OF FINISH	SIDE COATED (POLYURETHANE)
TYPE OF YARN	POLYAMIDE 6.6 HIGH TENACITY – 33 DTEX
WIDTH	158 CM
PATTERN	RIP STOP

TECHNICAL SPECIFICATIONS

COATED FABRIC'S WEIGHT	G/SQM	ISO 2286-2	45 +/-2
TEAR STRENGTH - WARP	DAN	ISO 4674	1 MINI
TEAR STRENGTH - WEFT	DAN	ISO 4674	2 MINI
ELONGATION ON BIAS 3 LBS	% INTERNAL METHOD NCV 044		4,5 +/-2
ELONGATION ON BIAS 5 LBS	% INTERNAL METHOD NCV 044		13 +/-2
ELONGATION ON BIAS 10 LBS	% INTERNAL METHOD NCV 044		19 +/-4
BREAK STRENGTH	DAN/5 CM	ISO 1421	40
WARP DIRECTION			
BREAK STRENGTH WEFT DIRECTION	DAN/5 CM	ISO 1421	33
AIR POROSITY	1/SQM/MN	2000 PA	20
	* UNDER	100 CM2	
	SURFACE		

TECHNICAL SPECIFICATIONS COLOR

DEEP BLUE	REF. 354	UV 5-6
GREEN	REF. 551	UV 5
GOLD	REF. 939	UV 5-6
SUNFLOWER	REF. 921	UV 5-6
ORANGE	REF. 744	UV 5
DRAGÓN RED	REF. 636	UV 5-6
WHITE	REF. 001	UV 4
GREY	REF. 120	UV 5
DARK GREY	REF. 121	UV 5-6
BLACK	REF. 102	UV 5-6
DARK RED	REF. 615	UV 4-5

FABRIC TECHNICAL DATA BOTTOM SURFACE
DESCRIPTION

SKYTEX 40 CLASSIC	REF. : F09017 - E38A
FABRIC	9017
TYPE OF FINISH	SIDE COATED (POLYURETHANE)
TYPE OF YARN	POLYAMIDE 6.6 HIGH TENACITY – 33 DTEX
WIDTH	158 CM
PATTERN	RIP STOP

TECHNICAL SPECIFICATIONS

COATED FABRIC'S WEIGHT	G/SQM	ISO 2286-2	40 +/-2
TEAR STRENGTH - WARP	DAN	ISO 4674	2,8 +/-1
TEAR STRENGTH - WEFT	DAN	ISO 4674	2,8 +/-1
ELONGATION ON BIAS 3 LBS	% INTERNAL METHOD NCV 044		5 +/-3
ELONGATION ON BIAS 5 LBS	% INTERNAL METHOD NCV 044		12,5 +/-4
ELONGATION ON BIAS 10 LBS	% INTERNAL METHOD NCV 044		24 +/-4
BREAK STRENGTH	DAN/5 CM	ISO 1421	38 MINI
WARP DIRECTION			
BREAK STRENGTH WEFT DIRECTION	DAN/5 CM	ISO 1421	38 MINI
AIR POROSITY	1/SQM/MN	2000 PA	40 MAXI
	* UNDER	100 CM2	
	SURFACE		

TECHNICAL SPECIFICATIONS COLOR

DEEP BLUE	REF. 354	UV 5-6
GREEN	REF. 551	UV 5
GOLD	REF. 939	UV 5-6
SUNFLOWER	REF. 921	UV 5-6
ORANGE	REF. 744	UV 5
DRAGÓN RED	REF. 636	UV 5-6
WHITE	REF. 001	UV 4
GREY	REF. 120	UV 5
DARK GREY	REF. 121	UV 5-6
BLACK	REF. 102	UV 5-6
DARK RED	REF. 615	UV 4-5

MAILLON TECHNICAL DATA

DESCRIPTION

MAILLON	DELTA
CODE	MR14
MATERIAL	ACERO INOX
SIZE	4,3 M/M
WEIGHT	12 G/PC

TECHNICAL SPECIFICATIONS

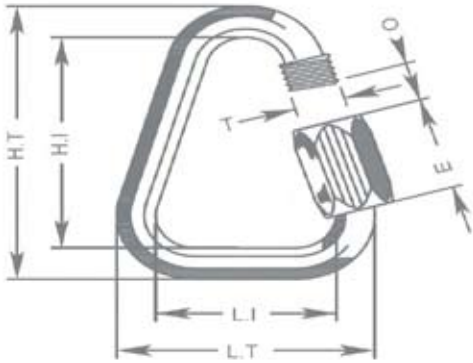

DIMENSIONS	M/M
L.T.	28
L.I.	20
H.T.	38
H.I.	30
O	4
E	11
T	4
LOAD	KG
WORKING LIMIT	150
BREAKING	750

MATERIAL

AISI 304 STAINLESS STEEL STANDARD

CLOSING APPLIED BY MANUAL & ENTIRE SCREWING OF THE NUT TO GUARANTEE THE HIGHEST SAFETY (NO THREAD SHOULD BE OBVIOUS).

SYSTEMATIC CONTROL OF MAILLON QUICK-LINKS BEFORE EVERY FLIGHT.

THREAD TECHNICAL DATA

NAME	SERAFIL
N° OF REFERENCE	40
MATERIAL	POLYESTER
TYPE OF FINISH	SILK
LINEAR DENSITY	NM 41 / 3 (DTEX 244 * 3)
BREAKING STRENGTH	4.500 CN
ELONGATION	17,00%

NAME	SERAFIL
N° OF REFERENCE	60
MATERIAL	POLYESTER
TYPE OF FINISH	SILK
LINEAR DENSITY	NM 61 / 3 (DTEX 163 * 3)
BREAKING STRENGTH	3.000 CN
ELONGATION	17,00%

PROPRIETIES SERAFIL		
SOLIDITY ARTIFICIAL LIGHT	ISO 105 B02	> 5 - 6
SOLIDITY SWEAT	ISO 105 E04	> 4
SOLIDITY WASHING	ISO 105 C04	> 3
SOLIDITY GRAZE IN DRY	ISO 105 X12	> 4
SOLIDITY WASHING IN DRY	ISO 105 D01	> 3 - 4

TREATMENT WATER REPELLENT	WR
---------------------------	----

NAME	BONDED NYLON
N° OF REFERENCE	N/F-66
MATERIAL	NYLON
TYPE OF FINISH	SILK
LINEAR DENSITY	210D / 6
BREAKING STRENGTH	9,7 KG
ELONGATION	25/30 %

RISERS TECHNICAL DATA**RISERS**

N° OF REFERENCE	G-R 22
MATERIAL	POLYESTER
WIDTH	22 M/M
THICKNESS	1,52 M/M
BREAKING STRENGTH	1.100 DAN
ELONGATION	MAX. 15%
WEIGHT	25 G/M
COLOR	BLACK

COLOR INDICATOR

N° OF REFERENCE	IC-G 1-2
MATERIAL	POLYESTER
WIDTH	70 M/M
THICKNESS	0,80 M/M
BREAKING STRENGTH	130 DN
ELONGATION	35%
WEIGHT	32 G/M

LOOPS

N° OF REFERENCE	LKI - 10
MATERIAL	NYLON
WIDTH	10 M/M
BREAKING STRENGTH	84 KG
ELONGATION	25/35 %
WEIGHT	3 G/M
COLOR	WHITE

nIVIUK

niviuk.com

The importance of small details