

TECHNICAL SPECIFICATIONS

R-BUS



TECHNICAL DATA

R-BUS			31	34	37	40
CELLS	NUMBER		55	55	55	55
	CLOSED		8	8	8	8
	BOX		35	35	35	35
FLAT	AREA	m ²	31	34	37	40
	SPAN	m	12,94	13,55	14,14	14,7
	ASPECT RATIO		5,4	5,4	5,4	5,4
PROJECTED	AREA	m ²	26,97	29,58	32,19	34,8
	SPAN	m	10,56	11,06	11,54	12
	ASPECT RATIO		4,14	4,14	4,14	4,14
FLATTENING		%	15	15	15	15
CORD	MAXIMUM	m	2,97	3,11	3,24	3,37
	MINIMUM	m	0,65	0,68	0,71	0,74
	AVERAGE	m	2,40	2,51	2,62	2,72
LINES	TOTAL METERS	m	398	417	426	444
	HEIGHT	m	7,7	8,06	8,41	8,75
	NUMBER		288	288	288	288
	MAIN		3+1/5/3/2	3+1/5/3/2	3+1/5/3/2	3+1/5/3/2
	RISERS		A+A'/B/C/D	A+A'/B/C/D	A+A'/B/C/D	A+A'/B/C/D
RISERS	NUMBER	4	A+A'/B/C/D	A+A'/B/C/D	A+A'/B/C/D	A+A'/B/C/D
	TRIMS		105	105	105	105
	ACCELERATOR	m/m	NO	NO	NO	NO
	COURSE CORRECTION		YES	YES	SI	SI
TOTAL SPEED	350kg	km/h	74 ± 2	73 ± 2	72 (± 2)	71 (± 2)
MIN SINK	350kg	m/s	1,6	1,6	1,6	1,6
TOTAL WEIGHT	MINIMUM	kg	100	120	150	210
IN FLIGHT	MAXIMUM	kg	410	440	470	500
MAX. WEIGHT IN FLIGHT		kg	6,6	7,1	7,6	8,1
GLIDER WEIGHT			EN 926-1	EN 926-1	EN 926-1	EN 926-1
CERTIFICATION	8G MAXIMUM 328kg		DGAC	DGAC	DGAC	DGAC
	5,25G MAXIMUM 500kg		LOAD TEST	LOAD TEST	LOAD TEST	LOAD TEST

MATERIALS TECHNICAL DATA

CANOPY	FABRIC CODE	SUPPLIER
UPPER SURFACE	N20 DMF	DOMINICO TEX CO
BOTTOM SURFACE	N20 DMF	DOMINICO TEX CO
RIBS	30 DFM	DOMINICO TEX CO
DIAGONALS	30 DFM	DOMINICO TEX CO
LOOPS	LKI - 10	KOLON IND. (KOREA)
REINFORCEMENT LOOPS	W-420	D-P (GERMANY)
TRAILING EDGE REINFORCEMENT	MYLAR	D-P (GERMANY)
RIB REINFORCEMENT	LTN-0.8 STICK	SPORTWARE CO. (CHINA)
THREAD	SERAFIL 60	AMAN (GERMANY)

SUSPENSION LINES	FABRIC CODE	SUPPLIER
UPPER CASCADES	PPSL - 120	LIROS GMHB (GERMANY)
MIDDLE CASCADES	PPSL - 120	LIROS GMHB (GERMANY)
MIDDLE CASCADES	PPSL - 200	LIROS GMHB (GERMANY)
MIDDLE CASCADES	TNL - 80	TEIJIM LIMITED (JAPAN)
MIDDLE CASCADES	TNL - 140	TEIJIM LIMITED (JAPAN)
MAIN	TNL - 140	TEIJIM LIMITED (JAPAN)
MAIN	TNL - 220	TEIJIM LIMITED (JAPAN)
MAIN	TNL - 280	TEIJIM LIMITED (JAPAN)
MAIN	TNL - 400	TEIJIM LIMITED (JAPAN)
MAIN BREAK	TNL - 400	TEIJIM LIMITED (JAPAN)
THREAD	SERAFIL 60	AMAN (GERMANY)

RISERS	FABRIC CODE	SUPPLIER
MATERIAL	G-R 22	TECNI SANGLES (FRANCE)
COLOUR INDICATOR	PAD	TECNI SANGLES (FRANCE)
THREAD	V138	COATS (UK)
MAILLONS	MRI4	ANSUNG PRECISION (KOREA)
PULLEYS	RF25109	RONSTAN (AUSTRALIA)

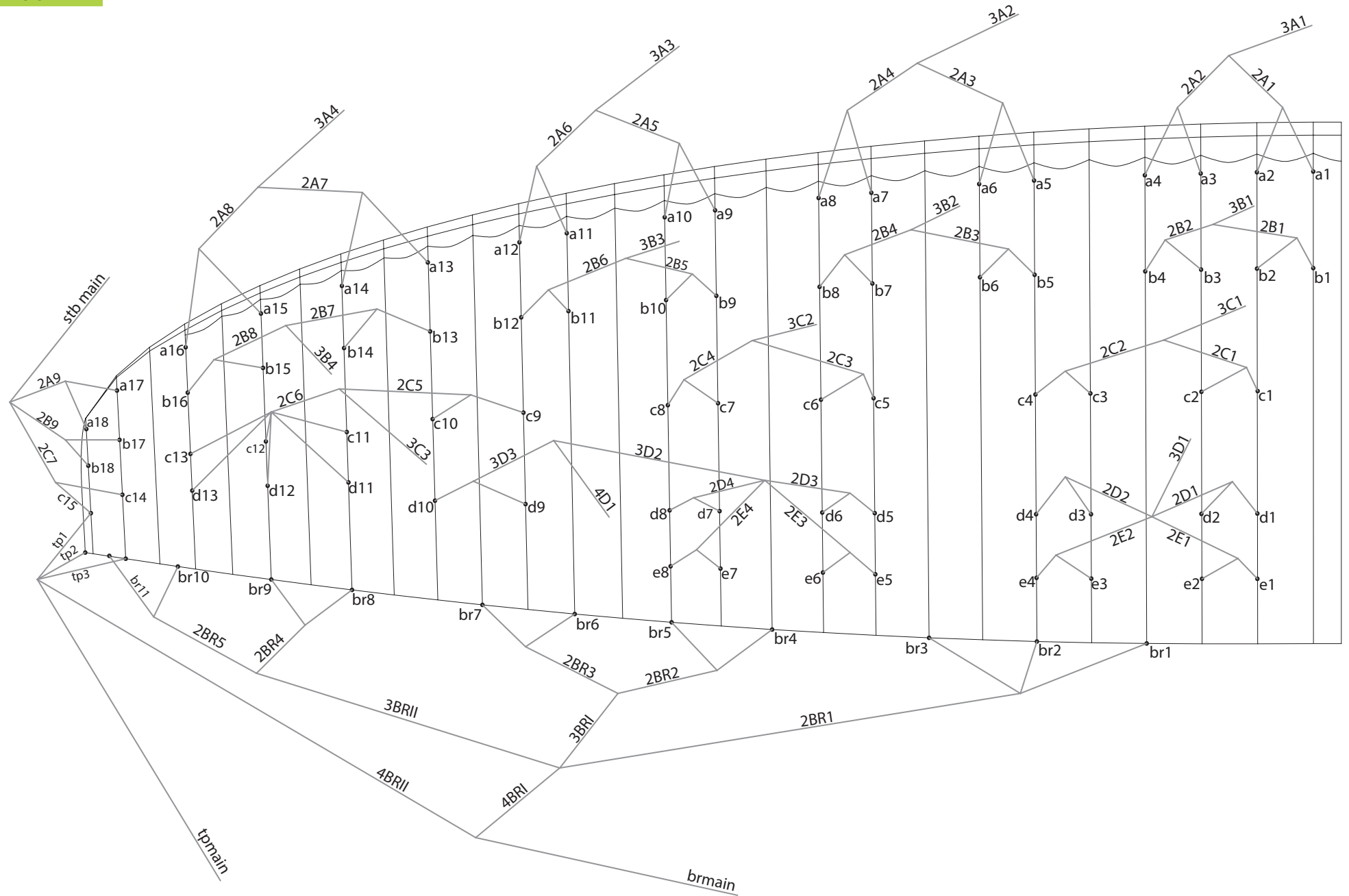

A	A'	B	C	D
3A1	3A4	3B1	3C1	3D1
3A2		3B2	3C2	4D1
3A3		3B3	3C3	
		3B4		
		stb main		

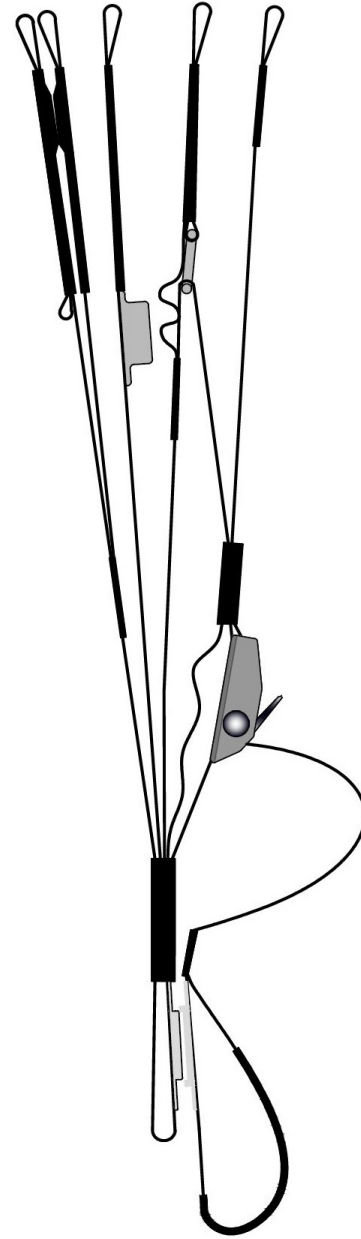

COLOURS TECHNICAL DATA

ROCKET	SB1	DRAGON RED	TOP	REF: 636
	SB2	DRAGON RED	BOTTOM	REF: 636
	SB3	BLACK	HORN	REF: 102
	SB4	LIMA	SHADOW	REF: 300
	SB5	LIMA	VOLUME SHADOW	REF: 300



MINT	SB1	LIMA	TOP	REF: 300
	SB2	LIMA	BOTTOM	REF: 300
	SB3	WHITE	HORN	REF: 001
	SB4	ROYAL BLUE	SHADOW	REF: 317
	SB5	ROYAL BLUE	VOLUME SHADOW	REF: 317

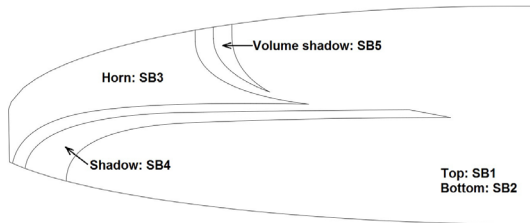

LEVEL RANGE**R-BUS**

31		34		37		40	
P.T.V.	KG/M2	P.T.V.	KG/M2	P.T.V.	KG/M2	P.T.V.	KG/M2
100	= 3,23	120	= 3,53	150	= 4,05	210	= 5,25
120	= 3,87	140	= 4,12	170	= 4,59	230	= 5,75
140	= 4,52	160	= 4,71	190	= 5,14	250	= 6,25
160	= 5,16	180	= 5,29	210	= 5,68	270	= 6,75
180	= 5,81	200	= 5,88	230	= 6,22	290	= 7,25
200	= 6,45	220	= 6,47	250	= 6,76	310	= 7,75
220	= 7,10	240	= 7,06	270	= 7,30	330	= 8,25

LINES TECHNICAL DATA

R-BUS 31

A					B					C					D					D					BRAKE				
REF.	MAT.	KG	COLOUR	M/M	REF.	MAT.	KG	COLOUR	M/M	REF.	MAT.	KG	COLOUR	M/M	REF.	MAT.	KG	COLOUR	M/M	REF.	MAT.	KG	COLOUR	M/M	REF.	MAT.	KG	COLOUR	M/M
a1	PPSL	120	YLW	521	b1	PPSL	120	BLUE	516	c1	PPSL	120	BLUE	435	d1	PPSL	120	BLUE	440	e1	PPSL	120	BLUE	467	br1	PPSL	120	RED	1856
a2	PPSL	120	YLW	460	b2	PPSL	120	BLUE	454	c2	PPSL	120	BLUE	365	d2	PPSL	120	BLUE	363	e2	PPSL	120	BLUE	396	br2	PPSL	120	RED	1521
a3	PPSL	120	YLW	475	b3	PPSL	120	BLUE	468	c3	PPSL	120	BLUE	367	d3	PPSL	120	BLUE	364	e3	PPSL	120	BLUE	398	br3	PPSL	120	RED	1373
a4	PPSL	120	YLW	512	b4	PPSL	120	BLUE	508	c4	PPSL	120	BLUE	426	d4	PPSL	120	BLUE	432	e4	PPSL	120	BLUE	458	br4	PPSL	120	RED	984
a5	PPSL	120	YLW	507	b5	PPSL	120	BLUE	502	c5	PPSL	120	BLUE	404	d5	PPSL	120	BLUE	414	e5	PPSL	120	BLUE	441	br5	PPSL	120	RED	876
a6	PPSL	120	YLW	448	b6	PPSL	120	BLUE	443	c6	PPSL	120	BLUE	355	d6	PPSL	120	BLUE	336	e6	PPSL	120	BLUE	364	br6	PPSL	120	RED	839
a7	PPSL	120	YLW	444	b7	PPSL	120	BLUE	436	c7	PPSL	120	BLUE	326	d7	PPSL	120	BLUE	344	e7	PPSL	120	BLUE	374	br7	PPSL	120	RED	897
a8	PPSL	120	YLW	484	b8	PPSL	120	BLUE	480	c8	PPSL	120	BLUE	387	d8	PPSL	120	BLUE	386	e8	PPSL	120	BLUE	407	br8	PPSL	120	RED	772
a9	PPSL	120	YLW	461	b9	PPSL	120	BLUE	444	c9	PPSL	120	BLUE	980	d9	PPSL	120	BLUE	701					br9	PPSL	120	RED	697	
a10	PPSL	120	YLW	424	b10	PPSL	120	BLUE	435	c10	PPSL	120	BLUE	840	d10	PPSL	120	BLUE	753					br10	PPSL	120	RED	748	
a11	PPSL	120	YLW	402	b11	PPSL	120	BLUE	410	c11	PPSL	120	BLUE	869	d11	PPSL	120	BLUE	943					br11	PPSL	120	RED	716	
a12	PPSL	120	YLW	428	b12	PPSL	120	BLUE	414	c12	PPSL	120	BLUE	811	d12	PPSL	120	BLUE	887										
a13	PPSL	120	YLW	1123	b13	PPSL	120	BLUE	1.037	c13	PPSL	120	BLUE	884	d13	PPSL	120	BLUE	951										
a14	PPSL	120	YLW	1008	b14	PPSL	120	BLUE	930	c14	PPSL	120	BLUE	320															
a15	PPSL	120	YLW	1003	b15	PPSL	120	BLUE	925	c15	PPSL	120	BLUE	313															
a16	PPSL	120	YLW	968	b16	PPSL	120	BLUE	903																				
a17	PPSL	120	YLW	466	b17	PPSL	120	BLUE	368																				
a18	PPSL	120	YLW	407	b18	PPSL	120	BLUE	342																				
2A1	PPSL	200	YLW	900	2B1	PPSL	200	BLUE	843	2C1	PPSL	200	BLUE	1103	2D1	TNL	140	BLUE	956	2E1	PPSL	120	BLUE	1064	2BR1	PPSL	120	RED	2669
2A2	PPSL	200	YLW	872	2B2	PPSL	200	BLUE	816	2C2	PPSL	200	BLUE	1088	2D2	TNL	140	BLUE	943	2E2	PPSL	120	BLUE	1050	2BR2	PPSL	120	RED	1034
2A3	PPSL	200	YLW	1443	2B3	PPSL	200	BLUE	1.353	2C3	TNL	140	BLUE	985	2D3	TNL	80	BLUE	937	2E3	PPSL	120	BLUE	1038	2BR3	PPSL	120	RED	1047
2A4	PPSL	200	YLW	1443	2B4	PPSL	200	BLUE	1361	2C4	TNL	140	BLUE	1.027	2D4	TNL	80	BLUE	885	2E4	PPSL	120	BLUE	978	2BR4	PPSL	120	RED	981
2A5	PPSL	200	YLW	1371	2B5	PPSL	200	BLUE	3165	2C5	TNL	140	BLUE	879										2BR5	PPSL	120	RED	805	
2A6	PPSL	200	YLW	1379	2B6	PPSL	200	BLUE	3178	2C6	TNL	140	BLUE	794	3D2	TNL	140	BLUE	1422					3BRI	PPSL	120	RED	1871	
2A7	PPSL	200	YLW	1048	2B7	PPSL	200	BLUE	965	2C7	PPSL	120	RED	1019	3D3	TNL	140	BLUE	1993					3BRII	PPSL	120	RED	1955	
2A8	PPSL	200	YLW	966	2B8	PPSL	200	BLUE	894															4BRI	TNL	400	RED	1763	
2A9	PPSL	120	YLW	838	2B9	PPSL	120	RED	906															4BRII	PPSL	120	RED	3458	
3A1	TNL	400	GREEN	5912	3B1	TNL	400	BLUE	5883	3C1	TNL	400	BLUE	5732	3D1	TNL	280	BLUE	5987	tp1	PPSL	120	RED	1275					
3A2	TNL	400	GREEN	5351	3B2	TNL	400	BLUE	5363	3C2	TNL	220	BLUE	5846	4D1	TNL	280	BLUE	4643	tp2	PPSL	120	RED	1155					
3A3	TNL	400	GREEN	5436	3B3	TNL	400	BLUE	3562	3C3	TNL	220	BLUE	5410						tp3	PPSL	120	RED	1272	brmain	TNL	400	RED	2597
3A4	TNL	280	GREEN	5004	3B4	TNL	280	BLUE	5134																				
					stb main	TNL	140	RED	5422										tpmain	TNL	280	RED	5747					knot point: 2397	

LINES TECHNICAL DATA

R-BUS

34

A					B					C					D					D					BRAKE						
REF.	MAT.	KG	COLOUR	M/M	REF.	MAT.	KG	COLOUR	M/M	REF.	MAT.	KG	COLOUR	M/M	REF.	MAT.	KG	COLOUR	M/M	REF.	MAT.	KG	COLOUR	M/M	REF.	MAT.	KG	COLOUR	M/M		
a1	PPSL	120	YLW	545	b1	PPSL	120	BLUE	540	c1	PPSL	120	BLUE	455	d1	PPSL	120	BLUE	461	e1	PPSL	120	BLUE	489	br1	PPSL	120	RED	1930		
a2	PPSL	120	YLW	483	b2	PPSL	120	BLUE	476	c2	PPSL	120	BLUE	383	d2	PPSL	120	BLUE	381	e2	PPSL	120	BLUE	415	br2	PPSL	120	RED	1581		
a3	PPSL	120	YLW	497	b3	PPSL	120	BLUE	490	c3	PPSL	120	BLUE	384	d3	PPSL	120	BLUE	381	e3	PPSL	120	BLUE	416	br3	PPSL	120	RED	1428		
a4	PPSL	120	YLW	536	b4	PPSL	120	BLUE	533	c4	PPSL	120	BLUE	446	d4	PPSL	120	BLUE	452	e4	PPSL	120	BLUE	479	br4	PPSL	120	RED	1023		
a5	PPSL	120	YLW	531	b5	PPSL	120	BLUE	525	c5	PPSL	120	BLUE	423	d5	PPSL	120	BLUE	434	e5	PPSL	120	BLUE	461	br5	PPSL	120	RED	912		
a6	PPSL	120	YLW	470	b6	PPSL	120	BLUE	464	c6	PPSL	120	BLUE	372	d6	PPSL	120	BLUE	352	e6	PPSL	120	BLUE	382	br6	PPSL	120	RED	872		
a7	PPSL	120	YLW	465	b7	PPSL	120	BLUE	456	c7	PPSL	120	BLUE	341	d7	PPSL	120	BLUE	360	e7	PPSL	120	BLUE	391	br7	PPSL	120	RED	933		
a8	PPSL	120	YLW	507	b8	PPSL	120	BLUE	503	c8	PPSL	120	BLUE	405	d8	PPSL	120	BLUE	404	e8	PPSL	120	BLUE	426	br8	PPSL	120	RED	802		
a9	PPSL	120	YLW	482	b9	PPSL	120	BLUE	465	c9	PPSL	120	BLUE	1026	d9	PPSL	120	BLUE	733						br9	PPSL	120	RED	726		
a10	PPSL	120	YLW	444	b10	PPSL	120	BLUE	456	c10	PPSL	120	BLUE	880	d10	PPSL	120	BLUE	789							br10	PPSL	120	RED	777	
a11	PPSL	120	YLW	420	b11	PPSL	120	BLUE	429	c11	PPSL	120	BLUE	910	d11	PPSL	120	BLUE	988							br11	PPSL	120	RED	744	
a12	PPSL	120	YLW	449	b12	PPSL	120	BLUE	434	c12	PPSL	120	BLUE	850	d12	PPSL	120	BLUE	929												
a13	PPSL	120	YLW	1176	b13	PPSL	120	BLUE	1.086	c13	PPSL	120	BLUE	926	d13	PPSL	120	BLUE	997												
a14	PPSL	120	YLW	1056	b14	PPSL	120	BLUE	974	c14	PPSL	120	BLUE	335																	
a15	PPSL	120	YLW	1050	b15	PPSL	120	BLUE	969	c15	PPSL	120	BLUE	327																	
a16	PPSL	120	YLW	1015	b16	PPSL	120	BLUE	946																						
a17	PPSL	120	YLW	488	b17	PPSL	120	BLUE	385																						
a18	PPSL	120	YLW	426	b18	PPSL	120	BLUE	358																						
2A1	PPSL	200	YLW	942	2B1	PPSL	200	BLUE	882	2C1	PPSL	200	BLUE	1154	2D1	TNL	140	BLUE	999	2E1	PPSL	120	BLUE	1113	2BR1	PPSL	120	RED	2774		
2A2	PPSL	200	YLW	914	2B2	PPSL	200	BLUE	856	2C2	PPSL	200	BLUE	1140	2D2	TNL	140	BLUE	989	2E2	PPSL	120	BLUE	1101	2BR2	PPSL	120	RED	1075		
2A3	PPSL	200	YLW	1510	2B3	PPSL	200	BLUE	1.415	2C3	TNL	140	BLUE	1030	2D3	TNL	80	BLUE	981	2E3	PPSL	120	BLUE	1086	2BR3	PPSL	120	RED	1089		
2A4	PPSL	200	YLW	1512	2B4	PPSL	200	BLUE	1426	2C4	TNL	140	BLUE	1.076	2D4	TNL	80	BLUE	927	2E4	PPSL	120	BLUE	1025	2BR4	PPSL	120	RED	1019		
2A5	PPSL	200	YLW	1435	2B5	PPSL	200	BLUE	3326	2C5	TNL	140	BLUE	920											2BR5	PPSL	120	RED	838		
2A6	PPSL	200	YLW	1445	2B6	PPSL	200	BLUE	3341	2C6	TNL	140	BLUE	832	3D2	TNL	140	BLUE	1487						3BRI	PPSL	120	RED	1945		
2A7	PPSL	200	YLW	1097	2B7	PPSL	200	BLUE	1011	2C7	PPSL	120	RED	1067	3D3	TNL	140	BLUE	2088						3BRII	PPSL	120	RED	2035		
2A8	PPSL	200	YLW	1012	2B8	PPSL	200	BLUE	937																4BRI	TNL	400	RED	1837		
2A9	PPSL	120	YLW	878	2B9	PPSL	120	RED	949																4BRII	PPSL	120	RED	3603		
3A1	TNL	400	GREEN	6209	3B1	TNL	400	BLUE	6178	3C1	TNL	400	BLUE	6022	3D1	TNL	280	BLUE	6290	tp1	PPSL	120	RED	1305							
3A2	TNL	400	GREEN	5625	3B2	TNL	400	BLUE	5638	3C2	TNL	220	BLUE	6146	4D1	TNL	280	BLUE	4888	tp2	PPSL	120	RED	1190							
3A3	TNL	400	GREEN	5717	3B3	TNL	400	BLUE	3742	3C3	TNL	220	BLUE	5692						tp3	PPSL	120	RED	1335	brmain	TNL	400	RED	2632		
3A4	TNL	280	GREEN	5267	3B4	TNL	280	BLUE	5403																						
					stb main	TNL	140	RED	5706											tpmain	TNL	280	RED	5975						knot point: 2432	

LINES TECHNICAL DATA

R-BUS 37

REF.	MAT.	kg	COLOUR	m/m	REF.	MAT.	kg	COLOUR	m/m	REF.	MAT.	kg	COLOUR	m/m	REF.	MAT.	kg	COLOUR	m/m	REF.	MAT.	kg	COLOUR	m/m					
A					B					C					D					E					BRAKE				
a1	PPSL	120	YELLOW	569	b1	PPSL	120	BLUE	563	c1	PPSL	120	BLUE	475	d1	PPSL	120	BLUE	481	e1	PPSL	120	BLUE	510	br1	PPSL	120	RED	2006
a2	PPSL	120	YELLOW	504	b2	PPSL	120	BLUE	497	c2	PPSL	120	BLUE	400	d2	PPSL	120	BLUE	398	e2	PPSL	120	BLUE	434	br2	PPSL	120	RED	1644
a3	PPSL	120	YELLOW	518	b3	PPSL	120	BLUE	510	c3	PPSL	120	BLUE	400	d3	PPSL	120	BLUE	397	e3	PPSL	120	BLUE	433	br3	PPSL	120	RED	1486
a4	PPSL	120	YELLOW	560	b4	PPSL	120	BLUE	556	c4	PPSL	120	BLUE	466	d4	PPSL	120	BLUE	472	e4	PPSL	120	BLUE	500	br4	PPSL	120	RED	1064
a5	PPSL	120	YELLOW	554	b5	PPSL	120	BLUE	548	c5	PPSL	120	BLUE	441	d5	PPSL	120	BLUE	453	e5	PPSL	120	BLUE	481	br5	PPSL	120	RED	950
a6	PPSL	120	YELLOW	490	b6	PPSL	120	BLUE	484	c6	PPSL	120	BLUE	389	d6	PPSL	120	BLUE	367	e6	PPSL	120	BLUE	398	br6	PPSL	120	RED	906
a7	PPSL	120	YELLOW	484	b7	PPSL	120	BLUE	476	c7	PPSL	120	BLUE	356	d7	PPSL	120	BLUE	375	e7	PPSL	120	BLUE	408	br7	PPSL	120	RED	970
a8	PPSL	120	YELLOW	529	b8	PPSL	120	BLUE	525	c8	PPSL	120	BLUE	422	d8	PPSL	120	BLUE	422	e8	PPSL	120	BLUE	445	br8	PPSL	120	RED	834
a9	PPSL	120	YELLOW	503	b9	PPSL	120	BLUE	485	c9	PPSL	120	BLUE	1070	d9	PPSL	120	BLUE	764						br9	PPSL	120	RED	755
a10	PPSL	120	YELLOW	464	b10	PPSL	120	BLUE	476	c10	PPSL	120	BLUE	918	d10	PPSL	120	BLUE	823						br10	PPSL	120	RED	807
a11	PPSL	120	YELLOW	438	b11	PPSL	120	BLUE	448	c11	PPSL	120	BLUE	949	d11	PPSL	120	BLUE	1031						br11	PPSL	120	RED	774
a12	PPSL	120	YELLOW	468	b12	PPSL	120	BLUE	452	c12	PPSL	120	BLUE	887	d12	PPSL	120	BLUE	970										
a13	PPSL	120	YELLOW	1226	b13	PPSL	120	BLUE	1.132	c13	PPSL	120	BLUE	967	d13	PPSL	120	BLUE	1040										
a14	PPSL	120	YELLOW	1101	b14	PPSL	120	BLUE	1.017	c14	PPSL	120	BLUE	350															
a15	PPSL	120	YELLOW	1096	b15	PPSL	120	BLUE	1.011	c15	PPSL	120	BLUE	341															
a16	PPSL	120	YELLOW	1059	b16	PPSL	120	BLUE	987																				
a17	PPSL	120	YELLOW	509	b17	PPSL	120	BLUE	402																				
a18	PPSL	120	YELLOW	445	b18	PPSL	120	BLUE	374																				
2A1	PPSL	200	YELLOW	982	2B1	PPSL	200	BLUE	919	2C1	PPSL	200	BLUE	1202	2D1	TNL	140	BLUE	1041	2E1	PPSL	120	BLUE	1159	2BR1	PPSL	120	RED	2882
2A2	PPSL	200	YELLOW	955	2B2	PPSL	200	BLUE	894	2C2	PPSL	200	BLUE	1191	2D2	TNL	140	BLUE	1032	2E2	PPSL	120	BLUE	1149	2BR2	PPSL	120	RED	1118
2A3	PPSL	200	YELLOW	1574	2B3	PPSL	200	BLUE	1.475	2C3	TNL	140	BLUE	1074	2D3	TNL	80	BLUE	1022	2E3	PPSL	120	BLUE	1133	2BR3	PPSL	120	RED	1134
2A4	PPSL	200	YELLOW	1579	2B4	PPSL	200	BLUE	1488	2C4	TNL	140	BLUE	1.123	2D4	TNL	80	BLUE	968	2E4	PPSL	120	BLUE	1070	2BR4	PPSL	120	RED	1059
2A5	PPSL	200	YELLOW	1497	2B5	PPSL	200	BLUE	3480	2C5	TNL	140	BLUE	960											2BR5	PPSL	120	RED	872
2A6	PPSL	200	YELLOW	1508	2B6	PPSL	200	BLUE	3497	2C6	TNL	140	BLUE	868	3D2	TNL	140	BLUE	1550						3BRI	PPSL	120	RED	2023
2A7	PPSL	200	YELLOW	1145	2B7	PPSL	200	BLUE	1054	2C7	PPSL	120	RED	1113	3D3	TNL	140	BLUE	2179						3BRII	PPSL	120	RED	2118
2A8	PPSL	200	YELLOW	1056	2B8	PPSL	200	BLUE	978																4BRI	TNL	400	RED	1913
2A9	PPSL	120	YELLOW	916	2B9	PPSL	120	RED	990																4BRII	PPSL	120	RED	3753
3A1	TNL	400	GREEN	6493	3B1	TNL	400	BLUE	6461	3C1	TNL	400	BLUE	6299	3D1	TNL	280	BLUE	6564	tp1	PPSL	120	RED	1,332					
3A2	TNL	400	GREEN	5888	3B2	TNL	400	BLUE	5901	3C2	TNL	220	BLUE	6433	4D1	TNL	280	BLUE	5106	tp2	PPSL	120	RED	1,251					
3A3	TNL	400	GREEN	5987	3B3	TNL	400	BLUE	3915	3C3	TNL	220	BLUE	5962						tp3	PPSL	120	RED	1,401	brmain	TNL	400	RED	2667
3A4	TNL	280	GREEN	5518	3B4	TNL	280	BLUE	5660																				
					stb main	TNL	140	RED	5977											tpmain	TNL	280	RED	6226					knot point: 2467

LINES TECHNICAL DATA

R-BUS 40

REF.	MAT.	kg	COLOUR	m/m	REF.	MAT.	kg	COLOUR	m/m	REF.	MAT.	kg	COLOUR	m/m	REF.	MAT.	kg	COLOUR	m/m	REF.	MAT.	kg	COLOUR	m/m					
A					B					C					D					E					BRAKE				
a1	PPSL	120	YELLOW	591	b1	PPSL	120	BLUE	586	c1	PPSL	120	BLUE	493	d1	PPSL	120	BLUE	500	e1	PPSL	120	BLUE	530	br1	PPSL	120	RED	2086
a2	PPSL	120	YELLOW	525	b2	PPSL	120	BLUE	518	c2	PPSL	120	BLUE	416	d2	PPSL	120	BLUE	414	e2	PPSL	120	BLUE	452	br2	PPSL	120	RED	1710
a3	PPSL	120	YELLOW	538	b3	PPSL	120	BLUE	530	c3	PPSL	120	BLUE	416	d3	PPSL	120	BLUE	412	e3	PPSL	120	BLUE	450	br3	PPSL	120	RED	1546
a4	PPSL	120	YELLOW	582	b4	PPSL	120	BLUE	578	c4	PPSL	120	BLUE	484	d4	PPSL	120	BLUE	491	e4	PPSL	120	BLUE	520	br4	PPSL	120	RED	1107
a5	PPSL	120	YELLOW	576	b5	PPSL	120	BLUE	569	c5	PPSL	120	BLUE	459	d5	PPSL	120	BLUE	471	e5	PPSL	120	BLUE	500	br5	PPSL	120	RED	989
a6	PPSL	120	YELLOW	510	b6	PPSL	120	BLUE	504	c6	PPSL	120	BLUE	405	d6	PPSL	120	BLUE	382	e6	PPSL	120	BLUE	415	br6	PPSL	120	RED	942
a7	PPSL	120	YELLOW	503	b7	PPSL	120	BLUE	494	c7	PPSL	120	BLUE	370	d7	PPSL	120	BLUE	390	e7	PPSL	120	BLUE	424	br7	PPSL	120	RED	1009
a8	PPSL	120	YELLOW	550	b8	PPSL	120	BLUE	546	c8	PPSL	120	BLUE	439	d8	PPSL	120	BLUE	439	e8	PPSL	120	BLUE	462	br8	PPSL	120	RED	866
a9	PPSL	120	YELLOW	523	b9	PPSL	120	BLUE	504	c9	PPSL	120	BLUE	1113	d9	PPSL	120	BLUE	794						br9	PPSL	120	RED	786
a10	PPSL	120	YELLOW	482	b10	PPSL	120	BLUE	495	c10	PPSL	120	BLUE	955	d10	PPSL	120	BLUE	856						br10	PPSL	120	RED	839
a11	PPSL	120	YELLOW	456	b11	PPSL	120	BLUE	465	c11	PPSL	120	BLUE	987	d11	PPSL	120	BLUE	1072						br11	PPSL	120	RED	804
a12	PPSL	120	YELLOW	487	b12	PPSL	120	BLUE	471	c12	PPSL	120	BLUE	922	d12	PPSL	120	BLUE	1009										
a13	PPSL	120	YELLOW	1275	b13	PPSL	120	BLUE	1.177	c13	PPSL	120	BLUE	1006	d13	PPSL	120	BLUE	1082										
a14	PPSL	120	YELLOW	1145	b14	PPSL	120	BLUE	1.057	c14	PPSL	120	BLUE	364															
a15	PPSL	120	YELLOW	1140	b15	PPSL	120	BLUE	1.052	c15	PPSL	120	BLUE	355															
a16	PPSL	120	YELLOW	1102	b16	PPSL	120	BLUE	1.027																				
a17	PPSL	120	YELLOW	529	b17	PPSL	120	BLUE	418																				
a18	PPSL	120	YELLOW	462	b18	PPSL	120	BLUE	389																				
2A1	PPSL	200	YELLOW	1020	2B1	PPSL	200	BLUE	955	2C1	PPSL	200	BLUE	1249	2D1	TNL	140	BLUE	1081	2E1	PPSL	120	BLUE	1204	2BR1	PPSL	120	RED	2995
2A2	PPSL	200	YELLOW	994	2B2	PPSL	200	BLUE	930	2C2	PPSL	200	BLUE	1239	2D2	TNL	140	BLUE	1074	2E2	PPSL	120	BLUE	1196	2BR2	PPSL	120	RED	1162
2A3	PPSL	200	YELLOW	1636	2B3	PPSL	200	BLUE	1.533	2C3	TNL	140	BLUE	1116	2D3	TNL	80	BLUE	1062	2E3	PPSL	120	BLUE	1177	2BR3	PPSL	120	RED	1180
2A4	PPSL	200	YELLOW	1642	2B4	PPSL	200	BLUE	1549	2C4	TNL	140	BLUE	1.168	2D4	TNL	80	BLUE	1007	2E4	PPSL	120	BLUE	1113	2BR4	PPSL	120	RED	1101
2A5	PPSL	200	YELLOW	1555	2B5	PPSL	200	BLUE	3629	2C5	TNL	140	BLUE	998											2BR5	PPSL	120	RED	907
2A6	PPSL	200	YELLOW	1568	2B6	PPSL	200	BLUE	3647	2C6	TNL	140	BLUE	903	3D2	TNL	140	BLUE	1610						3BRI	PPSL	120	RED	2103
2A7	PPSL	200	YELLOW	1190	2B7	PPSL	200	BLUE	1096	2C7	PPSL	120	RED	1157	3D3	TNL	140	BLUE	2266						3BRII	PPSL	120	RED	2204
2A8	PPSL	200	YELLOW	1098	2B8	PPSL	200	BLUE	1017																4BRI	TNL	400	RED	1993
2A9	PPSL	120	YELLOW	952	2B9	PPSL	120	RED	1029																4BRII	PPSL	120	RED	3909
3A1	TNL	400	GREEN	6766	3B1	TNL	400	BLUE	6733	3C1	TNL	400	BLUE	6565	3D1	TNL	280	BLUE	6842	tp1	PPSL	120	RED	1,456					
3A2	TNL	400	GREEN	6140	3B2	TNL	400	BLUE	6154	3C2	TNL	220	BLUE	6708	4D1	TNL	280	BLUE	5331	tp2	PPSL	120	RED	1,316					
3A3	TNL	400	GREEN	6246	3B3	TNL	400	BLUE	4081	3C3	TNL	220	BLUE	6221						tp3	PPSL	120	RED	1,471	brmain	TNL	400	RED	2703
3A4	TNL	280	GREEN	5760	3B4	TNL	280	BLUE	5908																				
					stb main	TNL	140	RED	6237											tpmain	TNL	280	RED	6507					knot point: 2503

NIVIUK R-BUS 31

LINES HEIGHT m/m

	A	B	C	D	E	br Tip	br
1	7320	7229	7257	7372	7507	7016	8667
2	7259	7167	7187	7295	7436	6896	8332
3	7246	7154	7174	7283	7424	7013	8184
4	7283	7194	7233	7351	7484		8024
5	7288	7205	7224	7402	7528		7916
6	7229	7146	7175	7324	7451		7892
7	7225	7147	7188	7280	7401		7950
8	7265	7191	7249	7322	7434		7843
9	7255	7158	7258	7326			7768
10	7218	7149	7118	7378			7643
11	7204	7137	7062	7136			7611
12	7230	7141	7004	7080			
13	7162	7123	7077	7144			
14	7047	7016	6751				
15	6960	6940	6744				
16	6925	6918					
17	6716	6686					
18	6657	6660					

RISERS LENGTH m/m

	A	A'	B	C	D	
	350	350	350	350	350	STANDARD
	350	350	350	402	455	TRIMMER OPENED

NIVIUK R-BUS 34

LINES HEIGHT m/m

	A	B	C	D	E	br Tip	br
1	7683	7587	7618	7739	7881	7274	8955
2	7621	7523	7546	7659	7807	7159	8606
3	7607	7511	7533	7649	7796	7304	8453
4	7646	7554	7595	7720	7859		8287
5	7653	7565	7588	7776	7906		8176
6	7592	7504	7537	7694	7827		8150
7	7589	7507	7552	7648	7775		8211
8	7631	7554	7616	7692	7810		8100
9	7621	7520	7627	7698			8024
10	7583	7511	7481	7754			7894
11	7569	7499	7423	7501			7861
12	7598	7504	7363	7442			
13	7527	7487	7439	7510			
14	7407	7375	7098				
15	7316	7296	7090				
16	7281	7273					
17	7062	7030					
18	7000	7003					

RISERS LENGTH m/m

	A	A'	B	C	D	
	350	350	350	350	350	STANDARD
	350	350	350	402	455	TRIMMER OPENED

NIVIUK R-BUS 37

LINES HEIGHT m/m

	A	B	C	D	E	br Tip	br
1	8031	7930	7963	8075	8222	7552	9251
2	7966	7864	7888	7992	8146	7471	8889
3	7953	7852	7877	7982	8135	7621	8731
4	7995	7898	7943	8057	8202		8560
5	8003	7911	7937	8117	8254		8445
6	7939	7847	7885	8031	8171		8418
7	7938	7852	7901	7985	8118		8482
8	7983	7901	7967	8032	8155		8366
9	7974	7867	7981	8038			8288
10	7935	7858	7829	8097			8152
11	7920	7847	7768	7850			8118
12	7950	7851	7706	7789			
13	7876	7833	7786	7859			
14	7751	7718	7430				
15	7657	7636	7421				
16	7620	7612					
17	7392	7359					
18	7328	7331					

RISERS LENGTH m/m

	A	A'	B	C	D	
	350	350	350	350	350	STANDARD
	350	350	350	402	455	TRIMMER OPENED

NIVIUK R-BUS 40

LINES HEIGHT m/m

	A	B	C	D	E	br Tip	br
1	8364	8261	8294	8412	8565	7957	9559
2	8298	8193	8217	8326	8487	7817	9183
3	8285	8180	8207	8317	8477	7972	9019
4	8329	8228	8275	8396	8547		8843
5	8339	8243	8272	8460	8602		8725
6	8273	8178	8218	8371	8517		8696
7	8272	8184	8235	8324	8462		8763
8	8319	8236	8304	8373	8500		8642
9	8311	8201	8321	8380			8562
10	8270	8192	8163	8442			8421
11	8257	8180	8100	8185			8386
12	8288	8186	8035	8122			
13	8212	8168	8119	8195			
14	8082	8048	7748				
15	7985	7964	7739				
16	7947	7939					
17	7708	7674					
18	7641	7645					

RISERS LENGTH m/m

	A	A'	B	C	D	
	350	350	350	350	350	STANDARD
	350	350	350	402	455	TRIMMER OPENED

SUSPENSION TECHNICAL DATA

R-BUS

MATERIAL CODE		PPSL	PPSL	TNL	TNL	TNL	TNL	TNL
STRENGTH CODE		120	200	080	140	220	280	400
DIAMETER m/m	Ø	1,15	1,42	1,1	1,4	1,6	1,8	2,3
CORE MATERIAL		DYNEEMA	DYNEEMA	TECHNORA	TECHNORA	TECHNORA	TECHNORA	TECHNORA
SLEEVE MATERIAL		POLYESTER	POLYESTER	POLYESTER	POLYESTER	POLYESTER	POLYESTER	POLYESTER
WEIGHT g/m	TOTAL	1	1,6	1,1	1,2	1,6	2,7	4
BREAKING STRENGTH	MINIMUM	120	200	80	140	220	280	460
	MAXIMUM	159	241	92	160	250	320	470
STRENGTH AFTER								
5.000 BENDING CYCLES	TEST EN	135	191	36,7	76,1	114,2	134,7	160,1
ELONGATION AT	5 dan en %			0,3	0,2	0,2	0,2	0,05
	10 dan en %	0,2	0,24	0,5	0,3	0,3	0,3	0,1
	15 dan en %			0,7	0,5	0,5	0,4	0,2
	20 dan en %			1	0,6	0,6	0,4	0,2
	25 dan en %			1,3	0,8	0,7	0,5	0,3
	30 dan en %	0,6	0,55	2,3	1,5	1,2	0,9	0,6
	75 dan en %			2,8	2,3	1,8	1,3	0,8

MAILLON TECHNICAL DATA

DESCRIPTION

MAILLON	DELTA
CODE	MRI4
MATERIAL	STAINLESS STEEL
SIZE	4,3 m/m
WEIGHT	12 g/piece

TECHNICAL SPECIFICATIONS

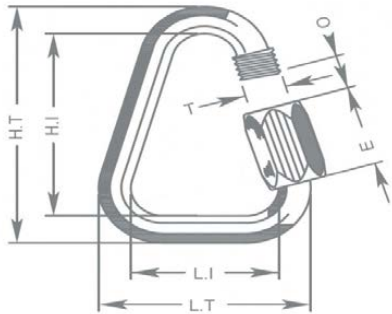

DIMENSIONS	m/m
L.T.	28
L.I.	20
H.T.	38
H.I.	30
O	4
E	11
T	4
LOAD	kg
WORKING LIMIT	150
BREAKING	750

MATERIAL

AISI 304 STAINLESS STEEL	STANDARD
--------------------------	----------

CLOSING APPLIED BY MANUAL & ENTIRE SCREWING OF THE NUT TO GUARANTEE THE HIGHEST SAFETY (NO THREAD SHOULD BE OBVIOUS)

SYSTEMATIC CONTROL OF MAILLON QUICK-LINKS BEFORE EVERY FLIGHT

THREAD TECHNICAL DATA**SAIL MAKING**

NAME	SERAFIL
N° OF REFERENCE	60
MATERIAL	POLYESTER
TYPE OF FINISH	SILK
LINEAR DENSITY	NM 61 / 3 (DTEX 163 * 3)
BREAKING STRENGTH	3,000 CN
ELONGATION	17,00%

SERAFIL PROPERTIES

SOLIDITY ARTIFICIAL LIGTH	ISO 105 B02 > 5 - 6
SOLIDITY SWEAT	ISO 105 E04 > 4
SOLIDITY WASHING	ISO 105 C04 > 3
SOLIDITY GRAZE IN DRY	ISO 105 X12 > 4
SOLIDITY WASHING IN DRY	ISO 105 D01 > 3 - 4

TREATMENT WATER REPELLENT	WR
---------------------------	----

RISERS MAKING

NAME	COATS BONDED C.F.P.
N° OF REFERENCE	V138
MATERIAL	POLYESTER
TYPE OF FINISH	SILK
BREAKING STRENGTH	9,5 kg
ELONGATION	19%

RISERS TECHNICAL DATA**RISERS**

N° OF REFERENCE	G-R 22
MATERIAL	POLYESTER
WIDTH	22 m/m
THICKNESS	1,52 m/m
BREAKING STRENGTH	1,100 DAN
ELONGATION	MAX. 15%
WEIGHT	25 g* L.M.
COLOUR	BLACK

COLOUR INDICATOR

N° OF REFERENCE	IC-G 1-2
MATERIAL	POLYESTER
WIDTH	70 m/m
THICKNESS	0,80 m/m
BREAKING STRENGTH	130 DN
ELONGATION	35 %
WEIGHT	32 g* L.M.
COLOUR	GREEN

LOOPS

N° OF REFERENCE	LKI - 10
MATERIAL	NYLON
WIDTH	10 m/m
BREAKING STRENGTH	84 kg
ELONGATION	30 %
WEIGHT	5,5 g/m
COLOUR	WHITE

